

**Zallys**<sup>®</sup>  
... the passion for moving



**M5**

Rimorchiatore elettrico

# M5

Z193.720



5,5 km/h



4.000 kg



15 %



- Per carichi fino a 4.000 kg.
- Versatile e compatto.
- Ruote pneumatiche.
- Selettore di velocità a 5 livelli.
- Ampia gamma di accessori e connessioni.

**Vista Frontale**



**Vista Laterale**



**Vista Posteriore**



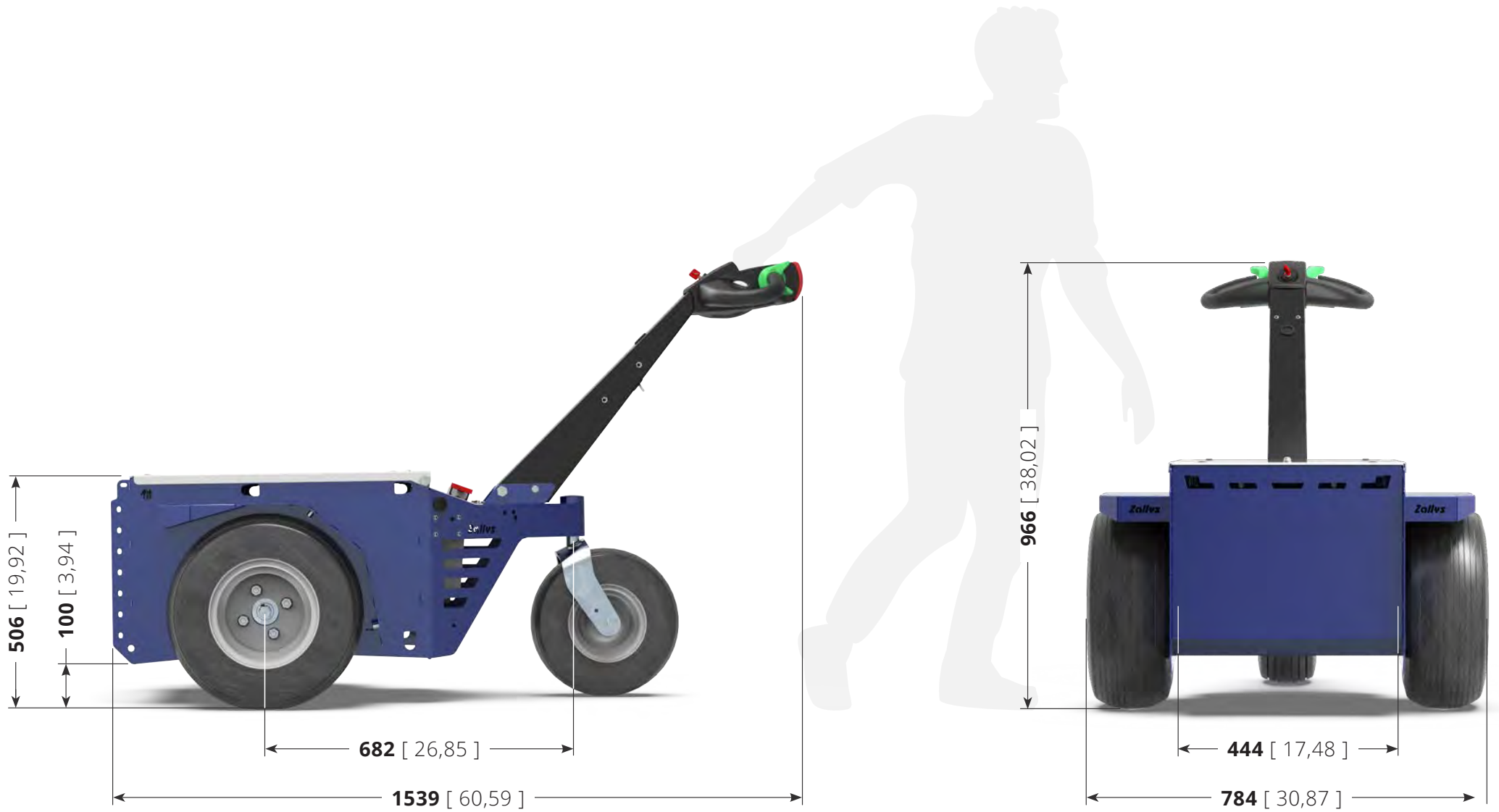

	TABLE: <b>Z193.720</b>	<b>M5</b>	Unit: mm [inch]
--	---------------------------	-----------	-----------------

## Settori principali



LOGISTICA DEI RIFIUTI



OSPEDALI



INDUSTRIA ALIMENTARE



MANUTENZIONE INDUSTRIALE



AEROPORTI

## Prestazioni di traino

Fermo restando invariata la forza al gancio espressa in N, la capacità di traino espressa in kg **può variare in base a:**

- **tipo di terreno** sul quale viene effettuato il traino;
- traino su suolo **piano o in pendenza**;
- utilizzo o meno di **zavorre**;
- **tipo di ruote** montate su macchina e carrello.

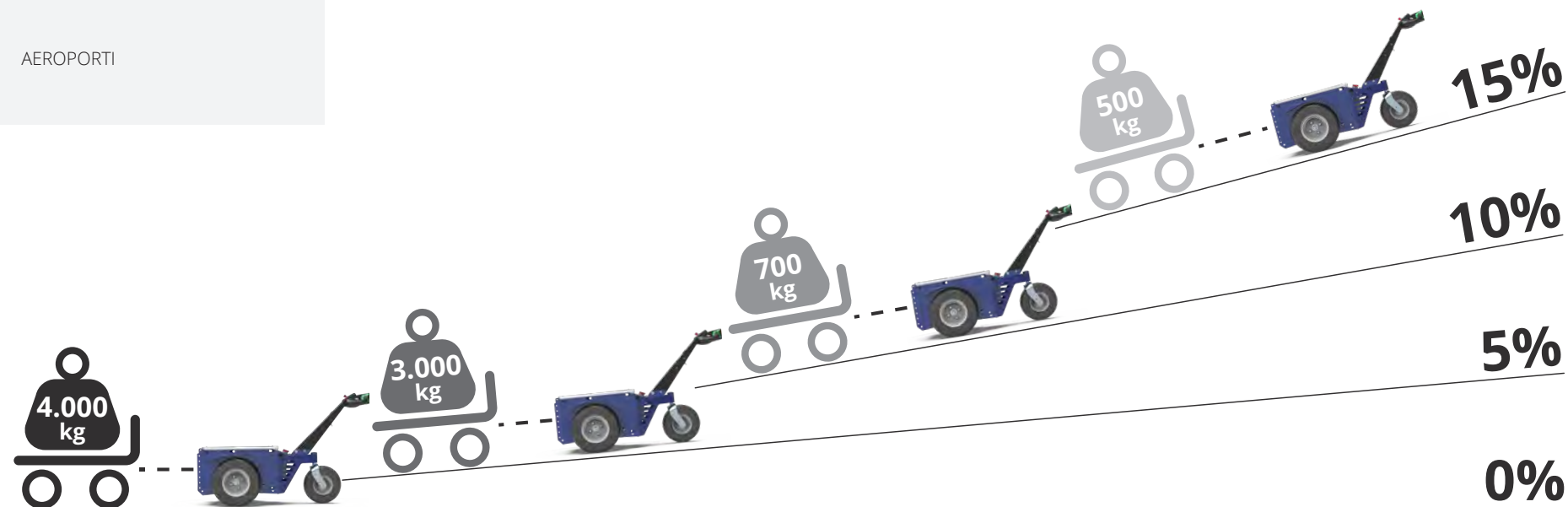

## Regolazione della velocità a 5 livelli

Sul nuovo timone di M5 firmato Zallys troviamo montato **di serie** un pulsante per regolare la velocità della macchina. Premendolo, ad ogni click si passa alla marcia successiva. Ciò permette una rapida e comoda selezione della velocità adeguata al tipo di manovra da affrontare. **Il sistema Flex-to-Go** è stato studiato per avere maggiore manovrabilità negli spazi ristretti e più velocità nei tragitti lunghi.

Ogni click aggiunge il **20% di velocità in più** rispetto alla marcia precedente.

### Rampa velocità:

20% - 40% - 60% - 80% - 100%

Una volta arrivati alla quinta marcia, premendo il pulsante si ritorna alla prima.

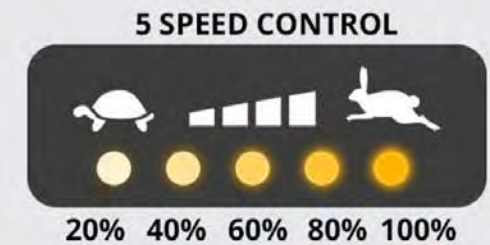

## Guida ergonomica

La testata Zallys è stata studiata e realizzata per rendere più ergonomico l'utilizzo della macchina da parte dell'operatore, garantendo il giusto **comfort su un uso prolungato** durante il turno di lavoro. Il suo **design ergonomico** permette di avere **tutti i pulsanti dei comandi a portata di mano**, il display con indicata la carica residua della batteria e la chiave per un'accensione veloce e comoda. La **struttura** è composta da **materiali resistenti** in caso di urti accidentali.

Chiave di accensione .....

Pulsante  
selezione 5 velocità .....

Pulsante anti-  
schiacciamento .....



..... Pannello di controllo

..... Pulsante avvisatore  
acustico

..... Comandi di marcia ad  
azione mantenuta



## Ruote pneumatiche

**M5** monta ruote pneumatiche, adatte sia per un utilizzo all'interno che all'esterno, garantendo sempre la massima trazione e un bassissimo livello di vibrazioni. Inoltre, sono molto resistenti e offrono prestazioni eccezionali su qualsiasi terreno. Grazie alla ruota pivottante e all'asse di trazione posto sul baricentro, la macchina può ruotare su se stessa.



## Autonomia per un'intera giornata di lavoro

**M5** è alimentato da due batterie da 105/130 Ah, che garantiscono alla macchina un'**autonomia di 8 ore lavorative ad uso continuativo**. In caso di utilizzo particolarmente intenso, è possibile passare a delle batterie con amperaggio maggiore, oppure montare un **pacco batterie estraibile e intercambiabile**, per avere la macchina sempre disponibile **24 ore su 24, 7 giorni su 7**. In entrambi i casi sono facili e sicure da ricaricare, grazie al caricabatterie esterno ad alta frequenza.



## Sistema di zavorre modulare

Il **sistema modulare Zallys** garantisce la **massima flessibilità** nell'aumentare le prestazioni del veicolo. Con un **peso unitario di soli 10 kg**, le singole zavorre sono leggere e possono essere equipaggiate **senza sforzi fisici da parte dell'operatore**, pur mantenendo tutta la loro efficacia.

# GANCI STANDARD



GANCIO CON  
SFERA-PERNO



GANCIO  
CON SPINA



GANCIO  
PER BIDONI  
DELLA SPAZZATURA

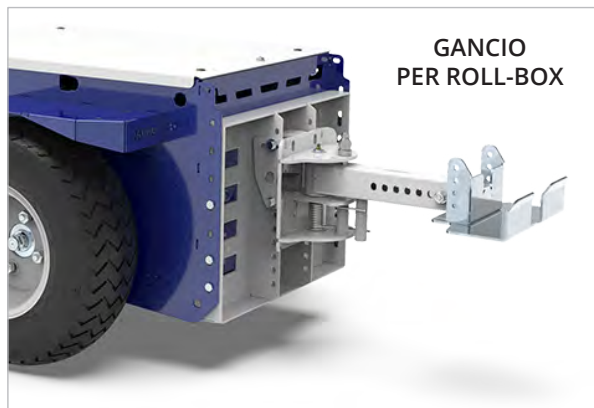

GANCIO  
PER ROLL-BOX

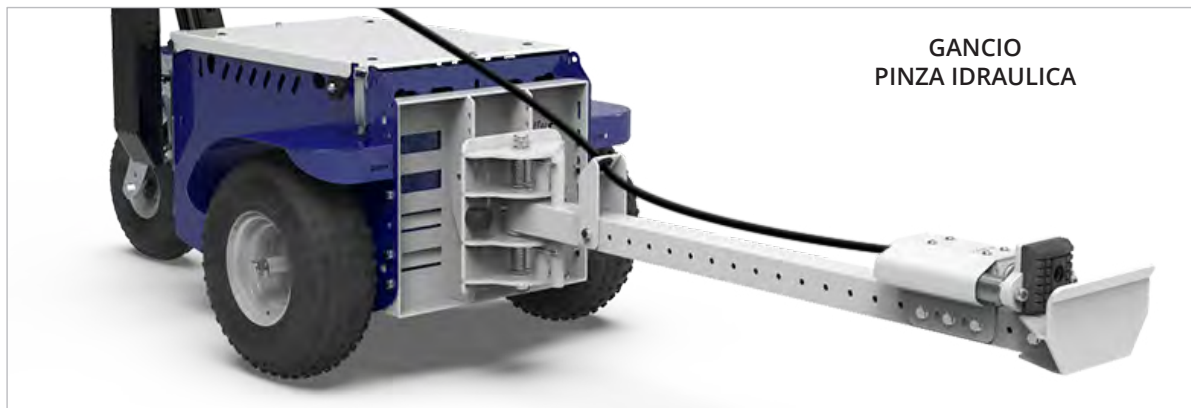

GANCIO  
PINZA IDRAULICA



# ACCESSORI





## **Esempi di applicazione**

---

nei vari settori produttivi



# INDUSTRIA METALLURGICA

**Zallys**  
... the passion for moving





# MANUTENZIONI INDUSTRIALI

**Zollis**  
... the passion for moving





# LOGISTICA DEI RIFIUTI

**Zollis**  
... the passion for moving







# Zallys®

• • • the passion for moving

Zallys srl srl - Via Palazzina 1, Sarcedo  
36030 (VI) - Italia

**Contatti:**

sales@zallys.com  
+39 0445 366785

**Web site:**

[www.zallys.com](http://www.zallys.com)





**Zallys**<sup>®</sup>  
... the passion for moving



**M5**

Industrial electric power pusher

# M5

Z193.720



5,5 km/h



4.000 kg



15 %



- For loads up to 4.000 kg.
- Versatile and compact.
- Pneumatic wheels.
- 5-levels speed adjustment.
- Wide range of accessories and connections.

👁 **Front View**



👁 **Side View**



👁 **Rear View**



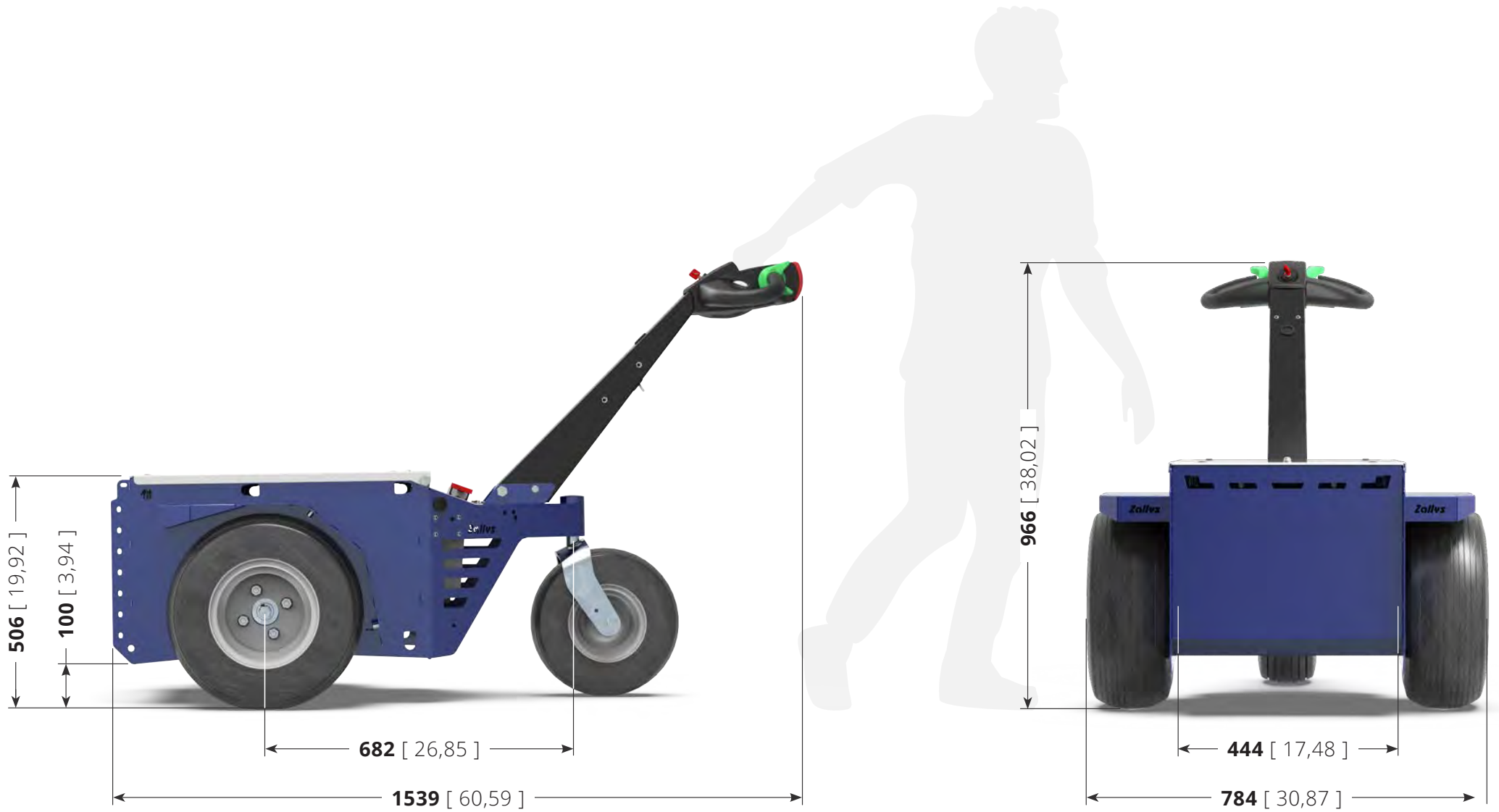

	TABLE: <b>Z193.720</b>	<b>M5</b>	Unit: mm [inch]
--	---------------------------	-----------	-----------------

## Main sectors



WASTE HANDLING



HOSPITALES



FOOD INDUSTRY



INDUSTRIAL  
MAINTENANCE



AIRPORTS

## Performances on slopes

While the force expressed in N at the hook remains unchanged, the following circumstances **may affect the towing capacity expressed in kg:**

- **type of ground** on which the towing is performed;
- towing on **flat ground or on a slope;**
- use (or not) of **ballasts;**
- **type of wheels** mounted on the vehicle and on the trailer.

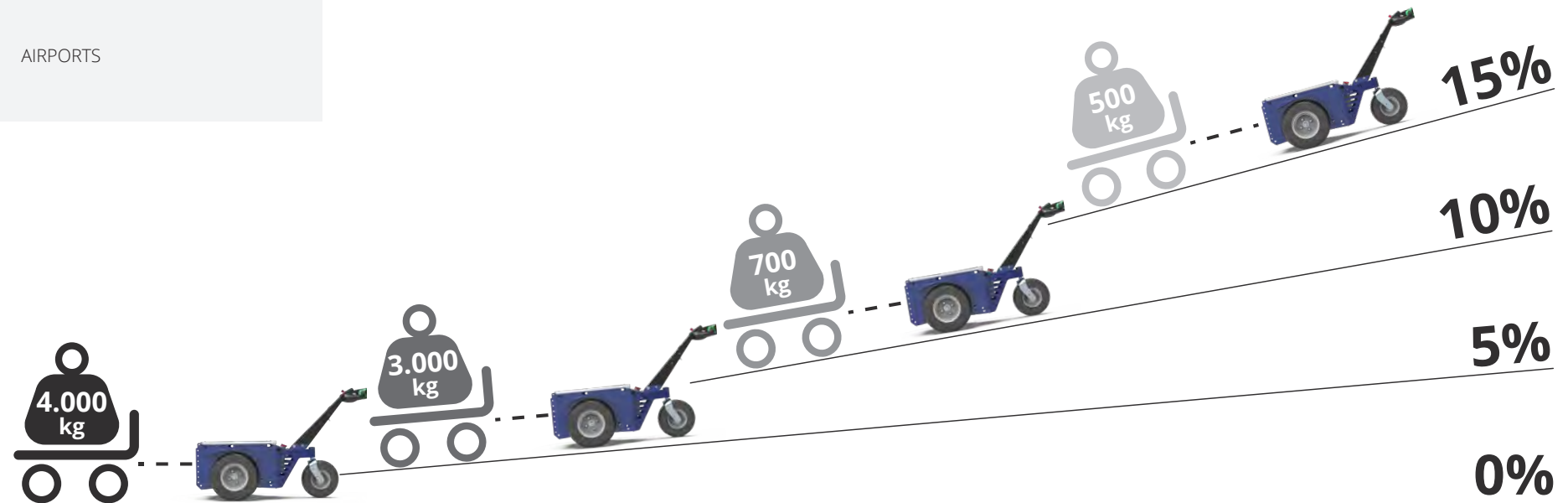

## 5 levels speed adjustment

On the new M5 tillerhead by Zallys is mounted **as standard** a button for the adjustment of the speed of the machine. By clicking it, at each click you switch to the next level. This allows a fast and easy selection of the correct speed based on the kind of manoeuvre. **The Flex-to-Go system** has been studied to give a better maneuverability in confined spaces and more speed on the longer journeys.

Each click adds **20% more speed**.

### Speed ramp:

20% - 40% - 60% - 80% - 100%

Once the maximum speed is reached, by pressing the button again it returns to 20%.

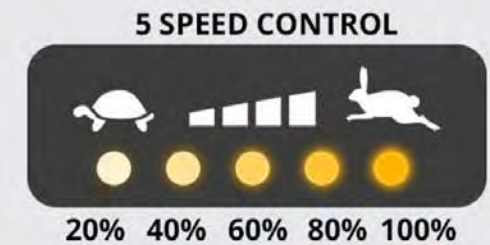

## Ergonomic driving

Zallys' tillerhead has been conceived and produced to make the use of the machine more ergonomic for the operator, guaranteeing the right **comfort while driving during the work shift**. Its **ergonomic design** allows to have **all the driving controls at your fingertips**, the display with the battery charge level and the power key for an easy and fast ignition. **The structure** is made of **resistant materials** in case of accidental bumps.

Power key

5 speed selection

Anti-crush reverse button



Dashboard

Acoustic alarm

Maintained action drive controls



## Pneumatic wheels

M5 is equipped with **pneumatic wheels**, suitable both for indoor and outdoor use, always guaranteeing the maximum grip and a really low level of vibrations. Moreover, they are very resistant and offer exceptional performances on every kind of ground. Thanks to the pivoting wheel and the traction axis located on the center of gravity, the machine can turn on itself.



## Autonomy for a full workday

M5 is powered by two 105/130 Ah batteries, which guarantee the machine for **8 hours operation at continuous use**. In case of a particularly intense use, it is possible to equip **higher amperage batteries**, or equip an **interchangeable and extractable battery pack, for a 24 / 7 operation**. In both cases they are easy and safe to recharge, thanks to the high frequency external battery pack.



## Modular ballast system

Zallys **modular system** guarantees **maximum flexibility** on increasing the vehicle's performances. With just **10 kg unit weight**, single ballasts are lightweight and can be equipped **without physical effort by the operator**, while maintaining all their effectiveness.

# STANDARD HITCH

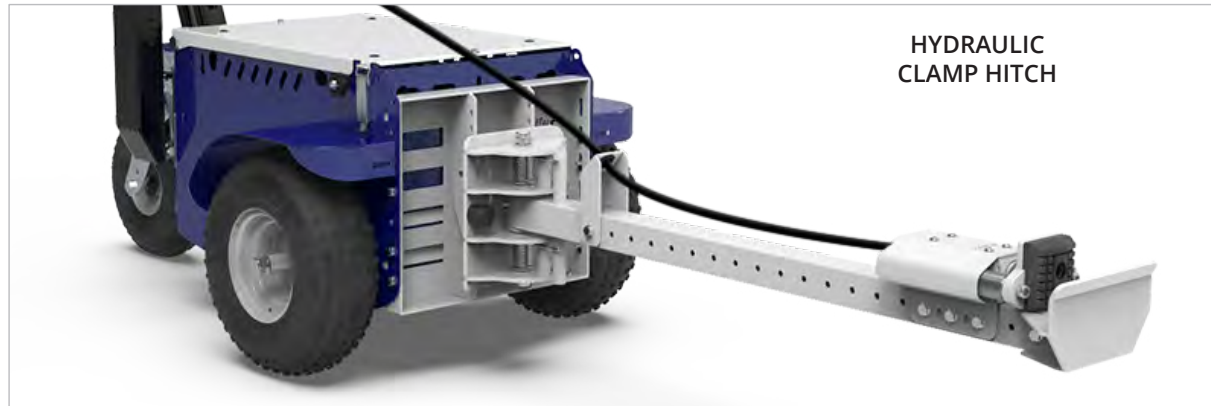
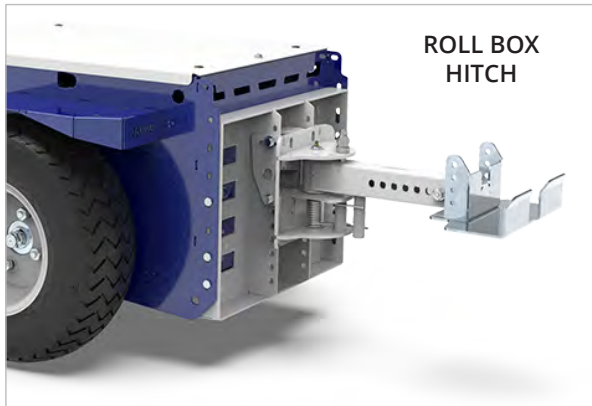



# ACCESSORIES





## Examples of applications

---

nei vari settori produttivi



# METALLURGICAL INDUSTRY

**Zallys**  
... the passion for moving





# INDUSTRIAL MAINTENANCE

**Zollis**  
... the passion for moving





# WASTE LOGISTICS

**Zollis**  
... the passion for moving







# Zallys®

• • • the passion for moving

Zallys srl srl - Via Palazzina 1, Sarcedo  
36030 (VI) - Italia

**Contacts:**

sales@zallys.com  
+39 0445 366785

**Web site:**

[www.zallys.com](http://www.zallys.com)





**Zallys**<sup>®</sup>  
... the passion for moving



**M5**

Tracteur industriel

# M5

Z193.720



5,5 km/h



4.000 kg



15 %



- Pour des charges jusqu'à 4.000 kg.
- Polyvalent et compact.
- Avec roues pneumatiques.
- Bouton pour le réglage à 5 vitesses.
- Large gamme des accessoires et attelages.

👁 **Vue de Face**



👁 **Vue Latérale**



👁 **Vue Arrière**



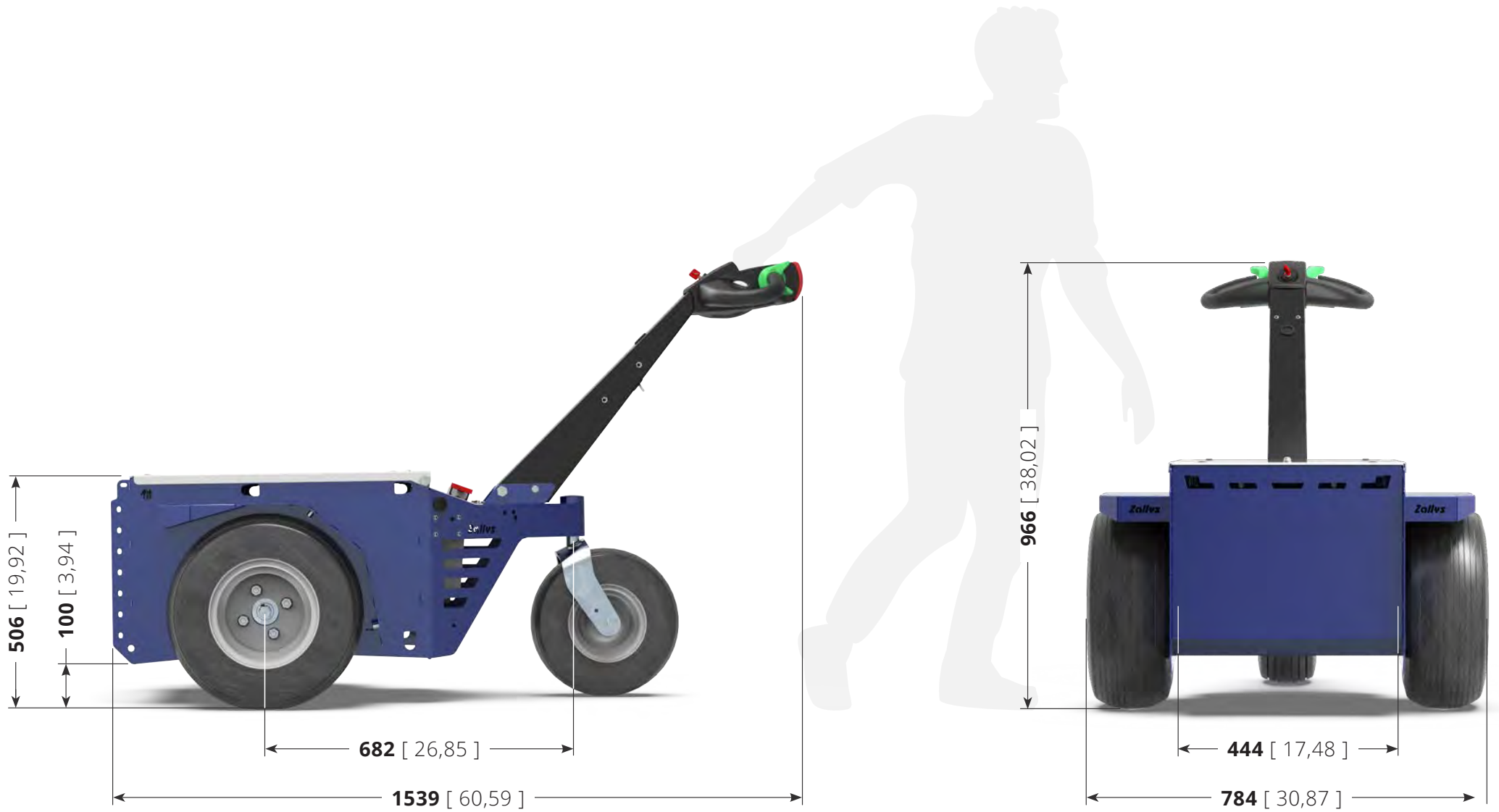

	TABLE: <b>Z193.720</b>	<b>M5</b>	Unit: mm [inch]
--	---------------------------	-----------	-----------------

## Principaux secteurs



GESTION DES DÉCHETS



HÔPITAUX



INDUSTRIE ALIMENTAIRE



MAINTENANCE INDUSTRIELLE



AÉROPORTS

## Performances de traction

Compte tenu des valeurs standard de l'effort de traction max au crochet en N, la capacité de traction, en kg, peut varier selon:

- **type de sol** où on travaille;
- **traction sur plan** or en pente;
- utilisation ou **pas de lests**;
- **typologies de roues** de la machine et du chariot.

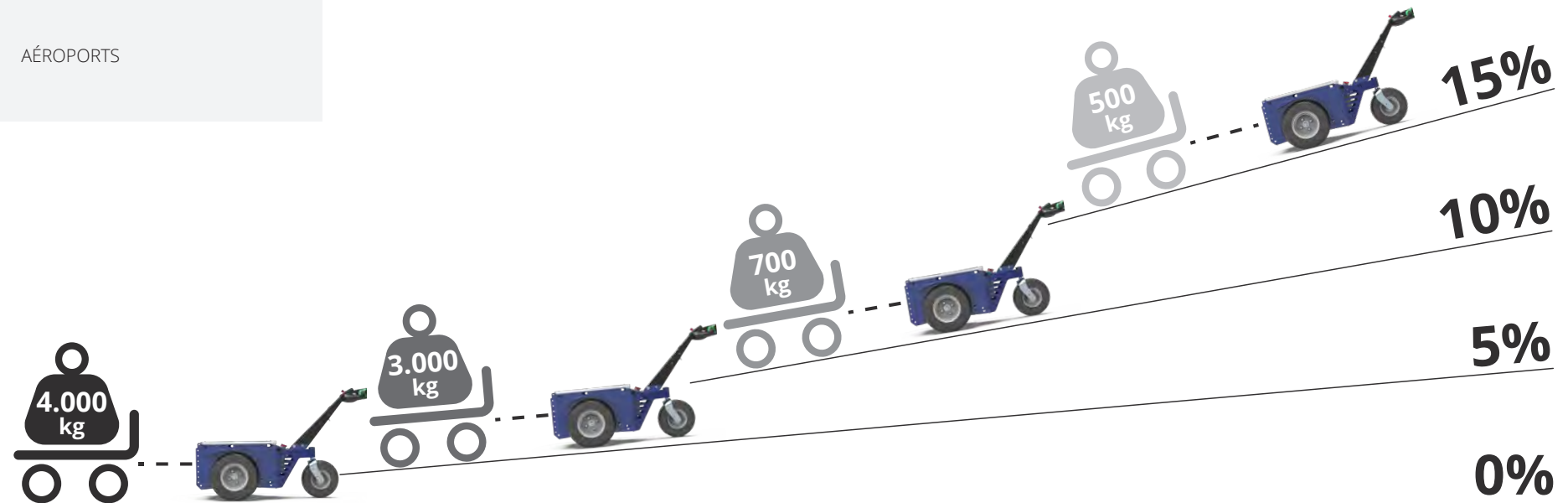

# Interrupteur 5 vitesses

Le bouton à 5 vitesses est monté de série sur le nouvel timon Zallys du M5. En y appuyant dessus, à chaque clique, vous passez au step suivant. Cela permet une sélection rapide et pratique de la vitesse correcte pour le type de manœuvre que l'opérateur doit faire. Le système Flex-to-Go a été conçu pour apporter une plus grande maniabilité dans les espaces étroits et plus de vitesse sur les longues distances.

Chaque clique ajoute 20% de vitesse de plus que l'étape précédente

## Valeurs vitesse:

20% - 40% - 60% - 80% - 100%

Una volta arrivati alla quinta marcia, premendo il pulsante si ritorna alla prima.

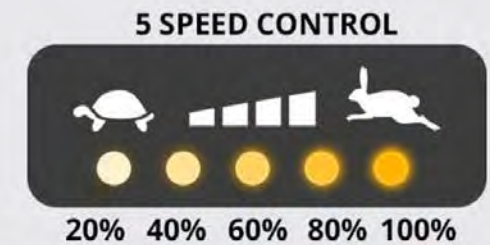

## Conduite ergonomique

La tête du timon Zallys est pensée pour rendre l'utilisation de la machine la plus ergonomique possible pour l'opérateur, en garantissant **le correct confort pendant un usage prolongé** sur le lieu du travail. **Toutes les commandes à portée de main**: dans le tableau de bord, des voyants à LED sont toujours visibles, le niveau de charge aussi et la clé pour permettre un allumage vite et confortable. La structure est faite avec **matériaux résistants** aux chocs accidentels.

Interrupteur à clé .....

Bouton pour  
selectionner la vitesse .....

Bouton anti-  
écrasement .....



..... Panneau de commande

..... Klaxon

..... Commande à action  
maintenue



## Roues pneumatiques

**M5** monte, en série, **roues pneumatiques**, aptes à être utilisés surtout à l'extérieur, sur de terrains boueux ou difficiles, mais parfaites aussi à l'intérieur; ces roues garantissent une adhérence maximale et des vibrations presque absentes. La machine peut tourner sur elle-même, grâce à la roue de direction et à l'axe de traction sur le centre de gravité.



## Autonomie des batteries pour la toute la journée

**M5** fonctionne avec 2 batteries au plomb 105/130 Ah: elles permettent de travailler pour **8 heures en continu**. En cas d'utilisation intensive, on peut équiper la machine avec **batteries plus puissantes** ou monter un **pack batteries amovible et interchangeable**, pour **travailler 24/7**. Dans les deux cas, pas de problèmes avec le rechargement, grâce au chargeur extérieur à haute fréquence.



## Système modulaire de lests

Le **système modulaire Zallys** garantit une flexibilité maximale en augmentant les performances du véhicule. Chaque lest a un **poids unitaire de 10 kg**: elles sont très légères et l'opérateur peut les manipuler sans aucun effort physique.

# CROCHETS STANDARD

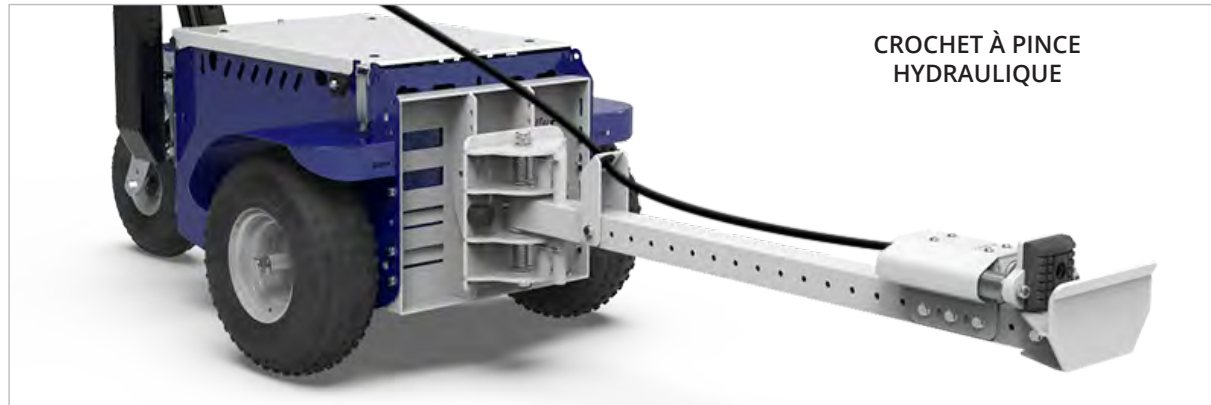
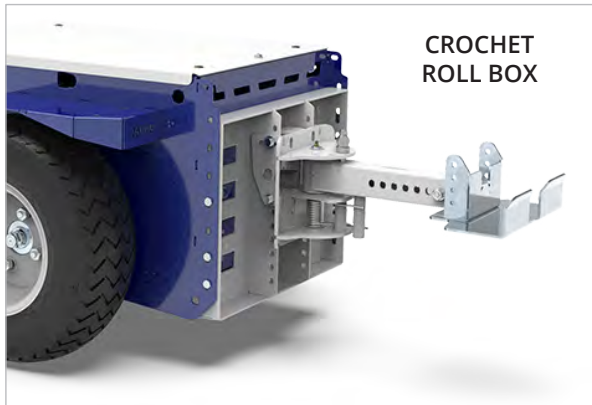
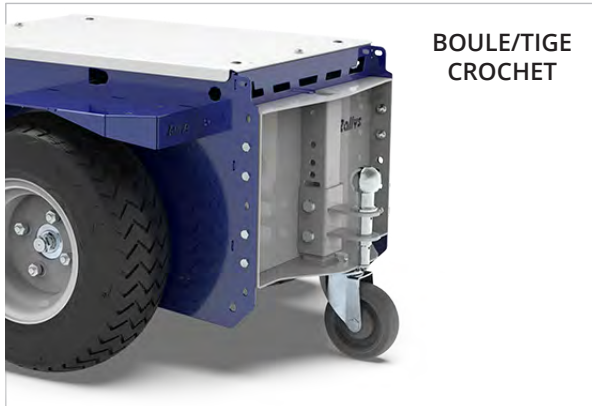



# ACCESSOIRES





## **Exemples d'applications**

---

Dans les différents secteurs productifs



# INDUSTRIE MÉTALLURGIQUE

**Zallys**  
... the passion for moving





# MAINTENANCES INDUSTRIELLES

Zollis  
... the passion for moving





# GESTION DE DÉCHETS

**Zallys**  
... the passion for moving







# Zallys®

• • • the passion for moving

Zallys srl srl - Via Palazzina 1, Sarcedo  
36030 (VI) - Italia

**Contatti:**

sales@zallys.com  
+39 0445 366785

**Web site:**

[www.zallys.com](http://www.zallys.com)





**Zallys**<sup>®</sup>  
... the passion for moving

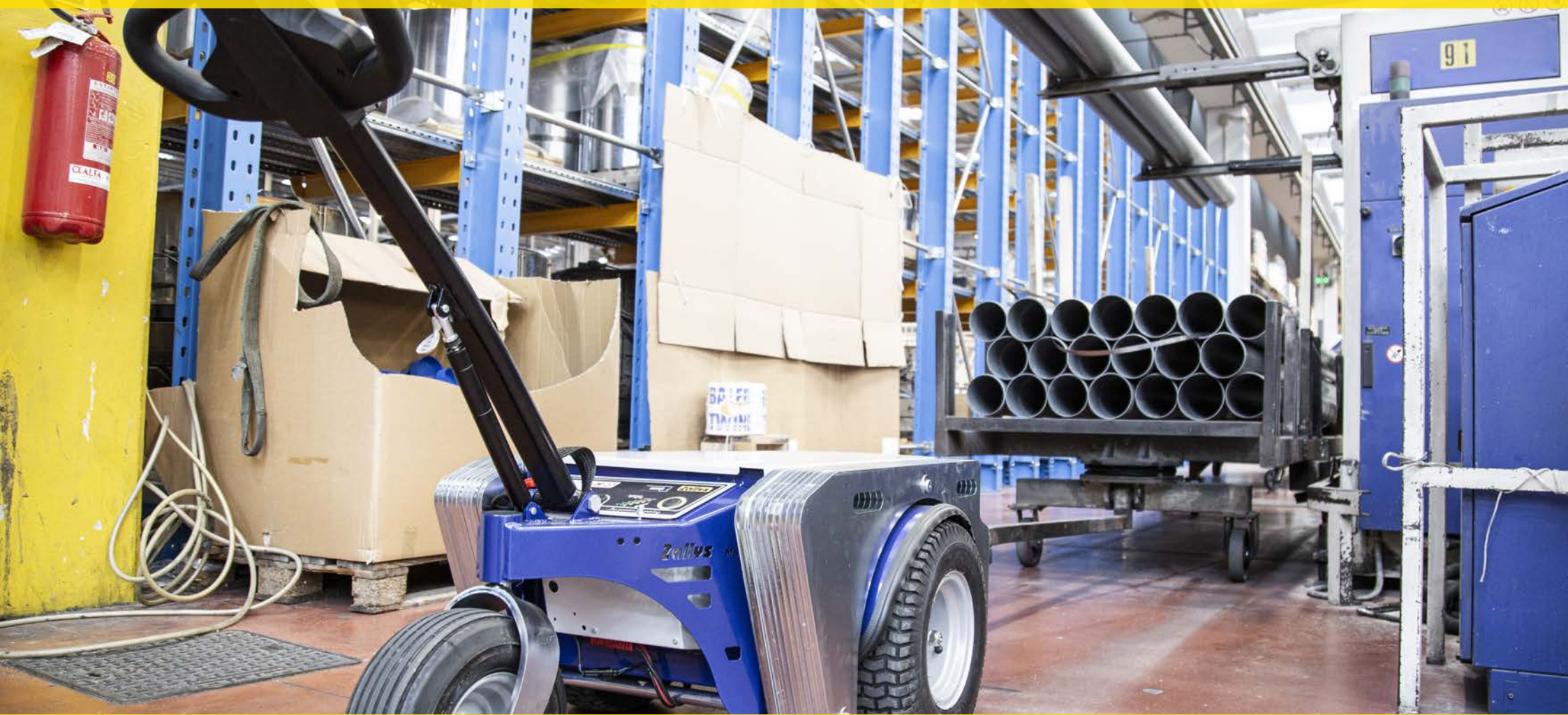

**M5**

Empujador de carga eléctrico

# M5

Z193.720



5,5 km/h



4.000 kg



15 %



- Para cargas de hasta 4.000 kg.
- Versátil y compacto
- Ruedas neumáticas
- Selector de velocidad de 5 niveles.
- Amplia gama de accesorios y conexiones.

**Vista Frontal**



**Vista Lateral**



**Vista Trasera**



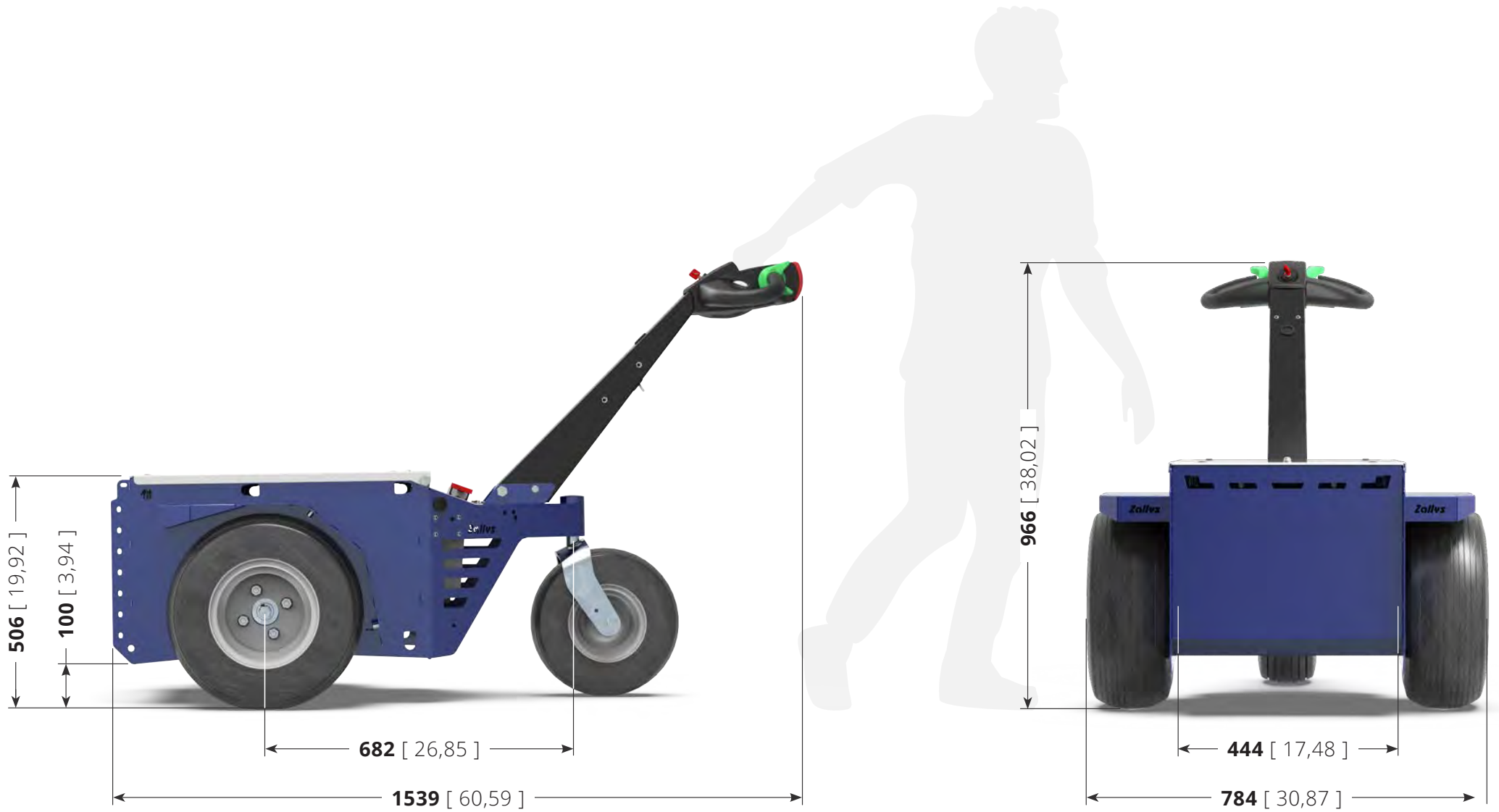

	TABLE: <b>Z193.720</b>	<b>M5</b>	Unit: mm [inch]
--	---------------------------	-----------	-----------------

## Sectores principales



LOGÍSTICA DE RESIDUOS



HOSPITALES



INDUSTRIA DE ALIMENTOS



MANTENIMIENTO INDUSTRIAL



AEROPUERTOS

# Rendimiento de remolque

Sin cambiar la fuerza sobre el gancho expresada en N, la capacidad de remolque expresada en kg **puede variar en**

**función de:**

- **tipo de terreno** en el que se lleva a cabo el remolque;
- **remolque en terreno** plano o inclinado;
- **uso o no** de contrapesos;
- **tipo de ruedas** montadas en la máquina y carro.

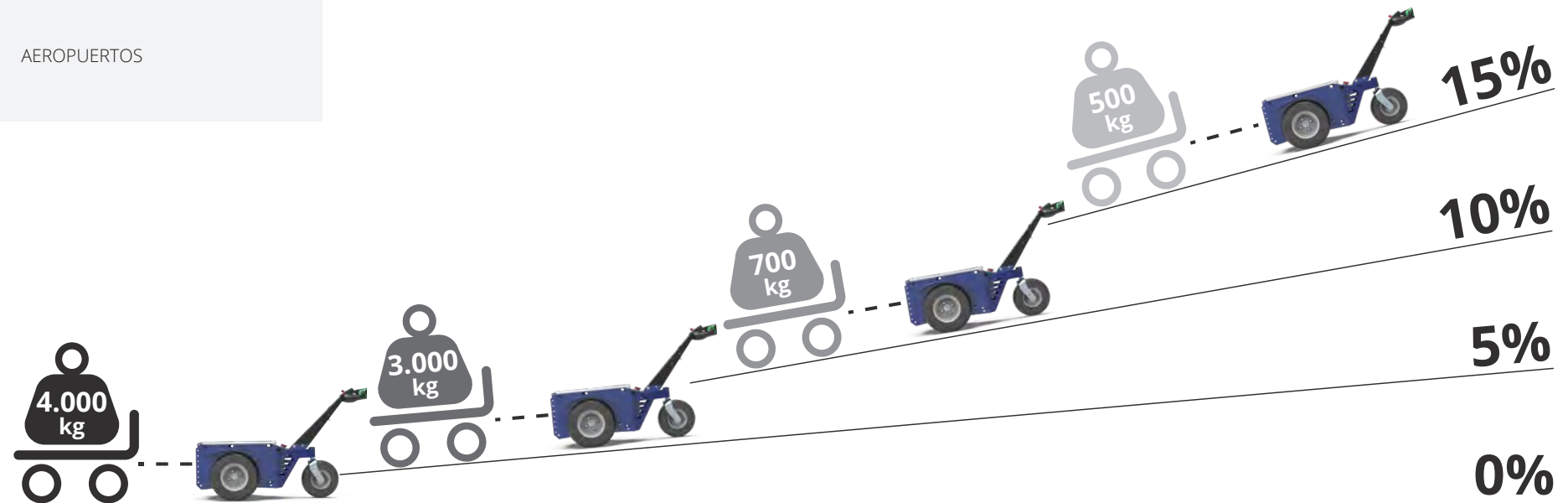

# Ajuste de velocidad de 5 niveles

En **el nuevo timón Zallys M5** encontramos un botón para ajustar la velocidad de la máquina **de serie**. Al presionarlo, cada clic cambia a la siguiente marcha. Esto permite una selección rápida y cómoda de la velocidad adecuada al tipo de maniobra a afrontar. El **sistema Flex-to-Go** ha sido diseñado para tener una mayor maniobrabilidad en espacios reducidos y más velocidad en viajes largos.

Cada clic **agrega un 20% más de velocidad** que la marcha anterior.

## Rampa de velocidad:

20% - 40% - 60% - 80% - 100%

Una vez en la quinta marcha, al presionar el botón se vuelve a la primera.

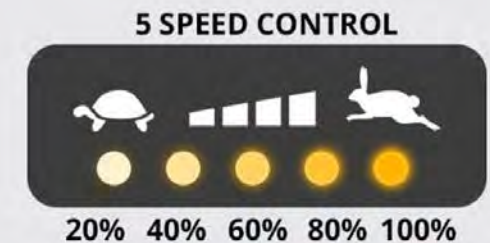

## Conducción ergonómica

El **cabezal Zallys** ha sido diseñado y construido para hacer más ergonómico el uso de la máquina por parte del operador, asegurando la **comodidad adecuada en un uso prolongado** durante el turno de trabajo. Su **diseño ergonómico** permite tener **todos los botones de control al alcance de la mano**, la pantalla indica la carga restante de la batería y la llave para un encendido rápido y conveniente. La **estructura** está fabricada con **materiales resistentes** en caso de impactos accidentales.

Llave de contacto .....

Botón de selección de velocidad .....

Botón anti-aplastamiento .....



..... Panel de control

..... Botón de la bocina

..... Mandos de marcha con acción mantenida



## Ruedas neumáticas

M5 está equipado con **ruedas neumáticas**, aptas tanto para uso interior como exterior, asegurando siempre la máxima tracción y un nivel muy bajo de vibraciones. Además, son muy duraderas y ofrecen un rendimiento excepcional en cualquier terreno. Gracias a la rueda pivotante y al eje de tracción situado en el centro de gravedad, la máquina puede girar sobre sí misma.



## Autonomía para todo un día de trabajo

M5 está alimentado por dos baterías de 105/130 Ah, que garantizan a la máquina una autonomía de **8 horas de trabajo para uso continuo**. En caso de uso particularmente intenso, es posible cambiar a baterías de mayor amperaje, o montar un paquete de **baterías extraíble e intercambiable**, para tener la máquina **siempre disponible las 24 horas del día, los 7 días de la semana**. En ambos casos son fáciles y seguros de recargar, gracias al cargador externo de alta frecuencia.



## Sistema de contrapesos modular

El **sistema modular de Zallys** garantiza la **máxima flexibilidad** para aumentar el rendimiento del vehículo. Con un **peso unitario de sólo 10 kg**, los contrapesos individuales son ligeros y el operador puede equiparlos **sin esfuerzo físico**, manteniendo toda su eficacia.

# GANCHOS ESTÁNDAR

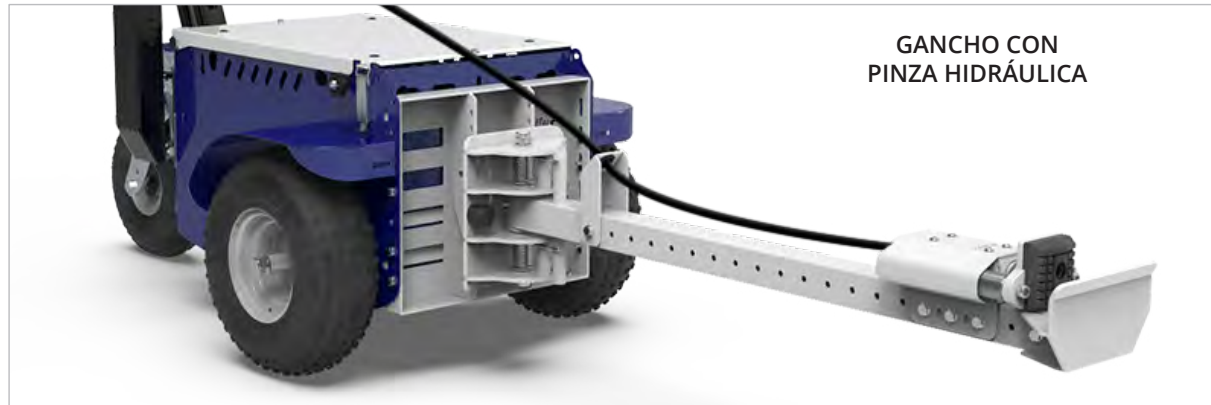
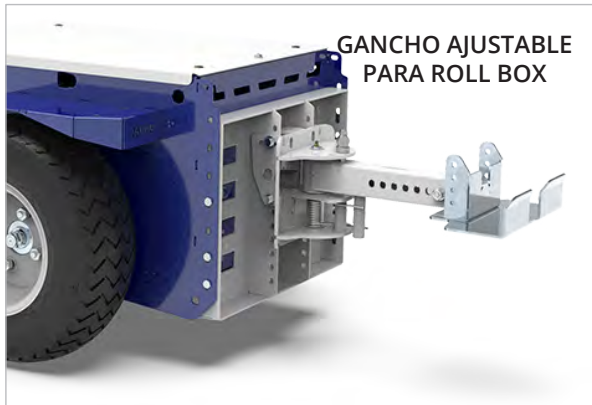



# ACCESORIOS





## **Ejemplos de aplicación**

---

en los distintos sectores productivos



# INDUSTRIA METALÚRGICA

**Zollis**  
... the passion for moving





# MANTENIMIENTO INDUSTRIAL

**Zollis**  
... the passion for moving





# LOGÍSTICA DE RESIDUOS

Zallys®  
... the passion for moving









• • • the passion for moving

Zallys srl srl - Via Palazzina 1, Sarcedo  
36030 (VI) - Italia

**Contatos:**

sales@zallys.com  
+39 0445 366785

**Web site:**

[www.zallys.com](http://www.zallys.com)





**Zallys**<sup>®</sup>  
... the passion for moving



**M5**

Elektrischer Schlepper

# M5

Z193.720



5,5 km/h



4.000 kg



15 %



- Für Lasten bis 4.000 kg..
- Vielseitig und kompakt.
- Lufträder.
- Taste zur 5-Gang-Einstellung
- Große Auswahl an Kupplungen.

👁 **Vorderansicht**



👁 **Seitenansicht**



👁 **Rückansicht**



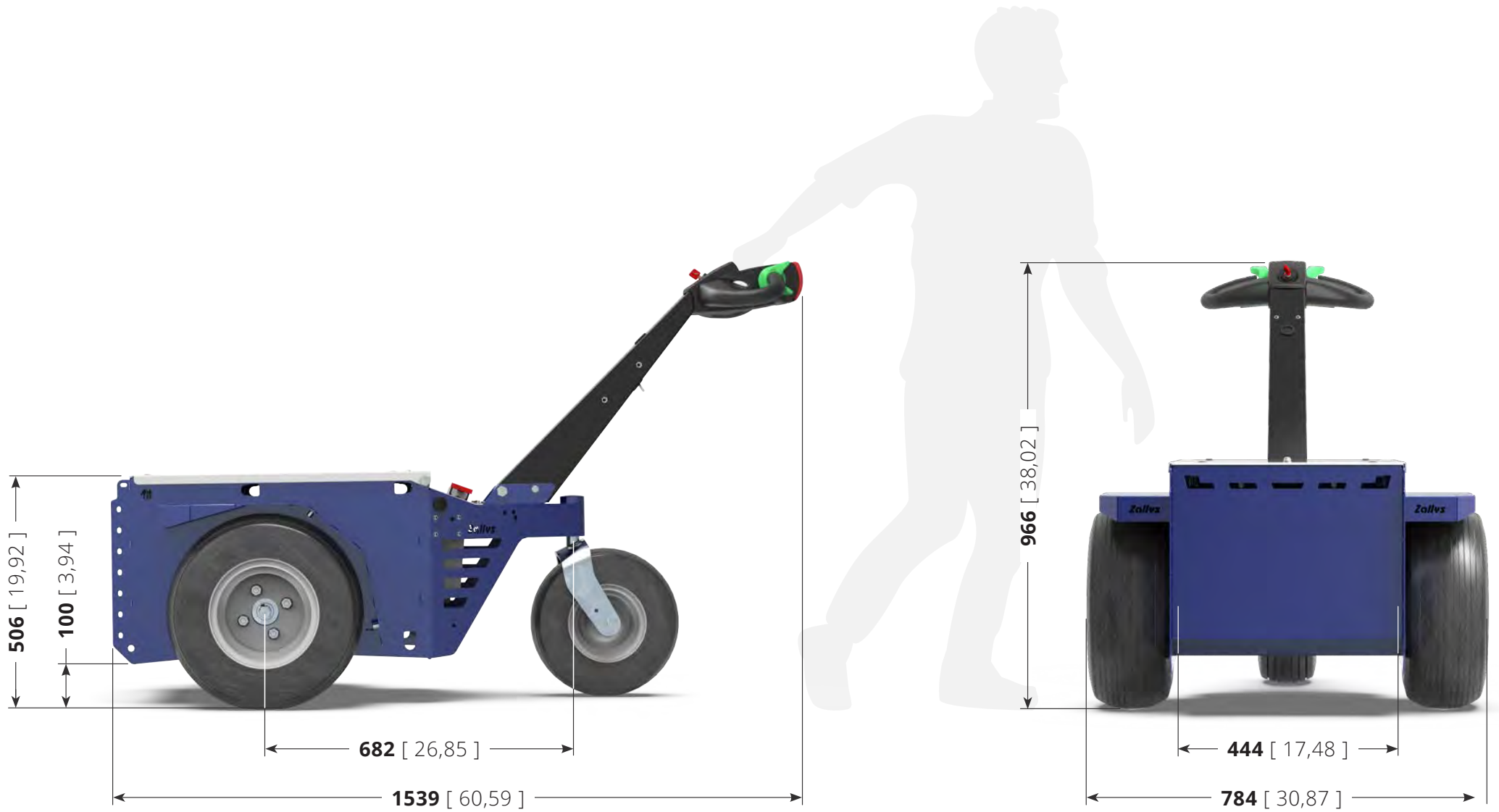

	TABLE: <b>Z193.720</b>	<b>M5</b>	Unit: mm [inch]
--	---------------------------	-----------	-----------------

## Hauptsektoren



ABFALLBEHANDLUNG



KRANKENHÄUSER



NAHRUNGSMITTELINDUSTRIE



INDUSTRIELLE  
IN STANDHALTUNG



FLUGHÄFEN

# Schleppleistungen

Bei unveränderter Hakenkraft in N kann die **Zugkraft in kg je nach:**

- **Art des Geländes**, auf dem geschleppt wird;
- Ebenem oder **geneigtem Boden**;
- Verwendung oder **Nichtverwendung von Ballast**;
- **Art der Räder** auf Maschine und Wagen montiert.

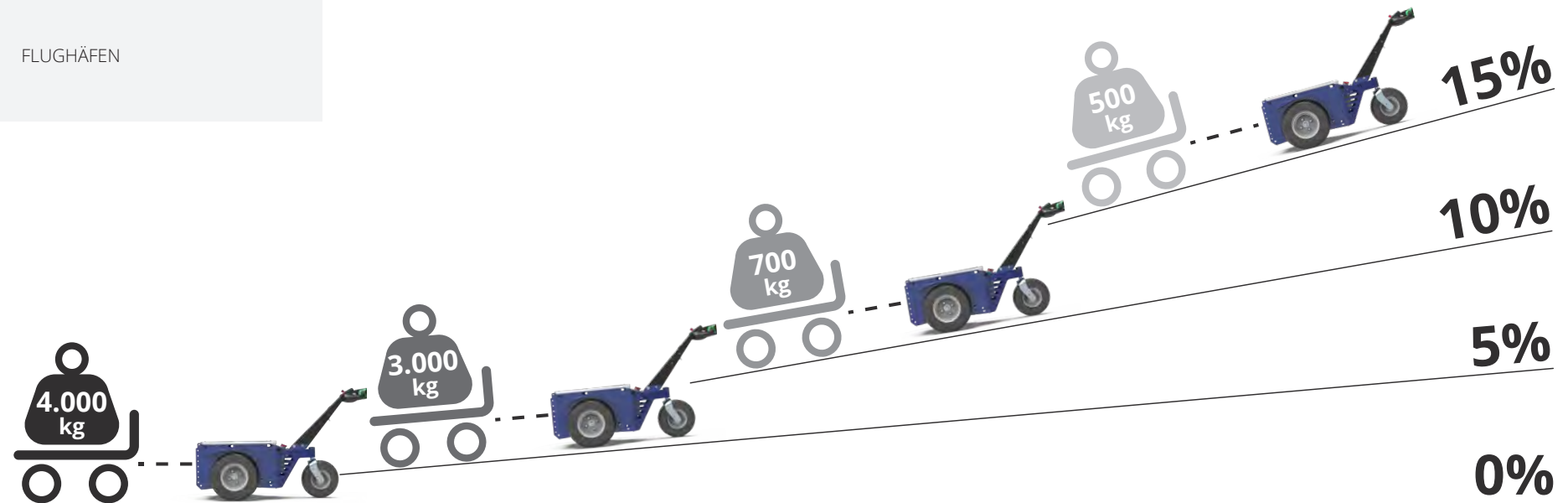

# Einstellung der 5 Geschwindigkeiten

Auf dem neuen M5-Steuerruder von Zallys finden wir serienmäßig eine Taste montiert, um die Geschwindigkeit des Fahrzeugs einzustellen. Mit jedem Klick gehen Sie zum nächsten Gang. Dies ermöglicht eine schnelle und bequeme Wahl der Geschwindigkeit, die der Art des zu bewältigenden Manövers angemessen ist. Das **Flex-to-Go-System** wurde entwickelt, um eine bessere Manövrierbarkeit auf engstem Raum und eine höhere Geschwindigkeit auf langen Strecken zu erreichen.

Jeder Klick erhöht die Geschwindigkeit um **20% gegenüber dem vorherigen Gang**.

## Geschwindigkeitsrampe:

20% - 40% - 60% - 80% - 100%

Sobald Sie den fünften Gang erreicht haben, drücken Sie den Knopf und kehren Sie in den ersten Gang zurück.

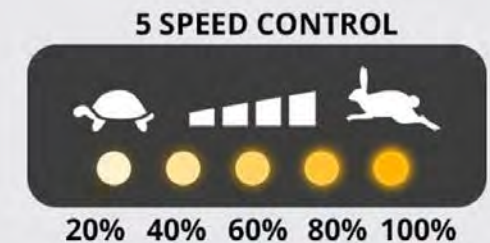

## Ergonomische Führung

Der Zallys-Kopf wurde entwickelt und entwickelt, um die Bedienung der Maschine durch den Bediener ergonomischer zu gestalten und den richtigen Komfort bei längerer Benutzung während der Schicht zu gewährleisten. **Das ergonomische Design ermöglicht es Ihnen**, alle Bedientasten griffbereit zu haben, das Display mit Angabe der verbleibenden Akkuladung und den Schlüssel für eine schnelle und bequeme Zündung. **Die Struktur besteht** aus widerstandsfähigen Werkstoffen gegen unbeabsichtigte Stöße.

Zündschlüssel

Taste zur 5-Gang-Einstellung

Anti-Zerquetschen-Knopf



Dashboard

Akustischer Warnknopf

Beibehaltene Aktionssteuerungen



## Lufträder

**M5** montiert Lufträder, die sowohl für den Einsatz im Innen- als auch im Aussenbereich geeignet sind und stets maximale Traktion und ein sehr niedriges Vibrationsniveau gewährleisten. Darüber hinaus sind sie sehr widerstandsfähig und bieten aussergewöhnliche Leistung auf jedem Gelände. Dank des Schwenkrades und der Antriebsachse im Schwerpunkt kann sich die Maschine selbst drehen.



## Autonomie für einen ganzen Arbeitstag

**M5** wird von zwei 105/130 Ah-Batterien gespeist, die der Maschine eine **Autonomie von 8 Arbeitsstunden bei Dauereinsatz garantieren**. Bei besonders intensiver Nutzung ist es möglich, **auf Akkus mit höherer Stromstärke umzusteigen** oder einen herausnehmbaren und austauschbaren Akkupack zu montieren, um die Maschine rund um die Uhr verfügbar zu halten. **In beiden Fällen sind sie dank des externen Hochfrequenz-Ladegeräts** einfach und sicher aufzuladen.



## Modulare Ballstsystem

Das **modulare System von Zallys** bietet maximale Flexibilität bei der Steigerung der Fahrzeugleistung. **Mit einem Stückgewicht von nur 10 kg sind die einzelnen Ballastgeräte** leicht und können ohne körperliche Anstrengung des Bedieners ausgerüstet werden.

# STANDARDHAKEN

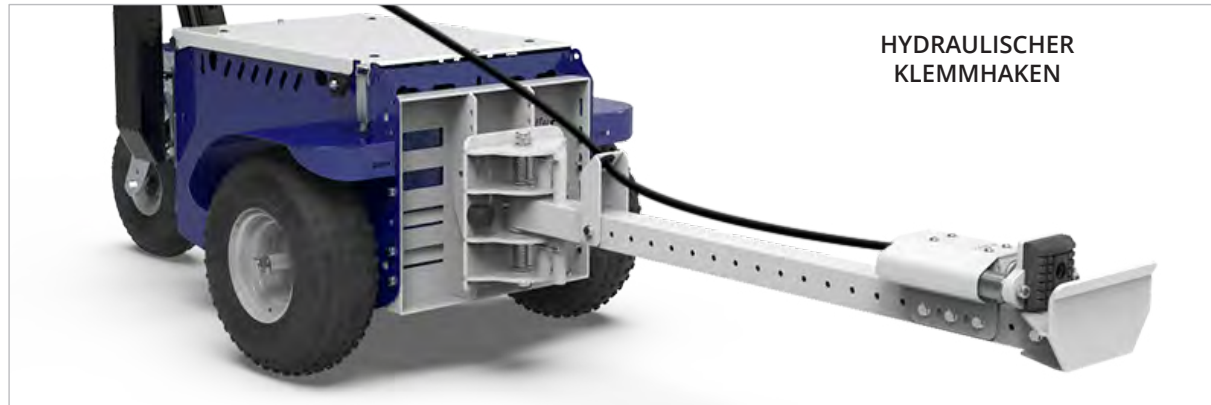
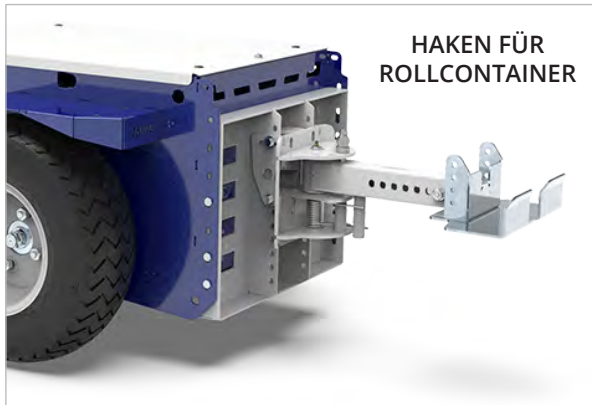
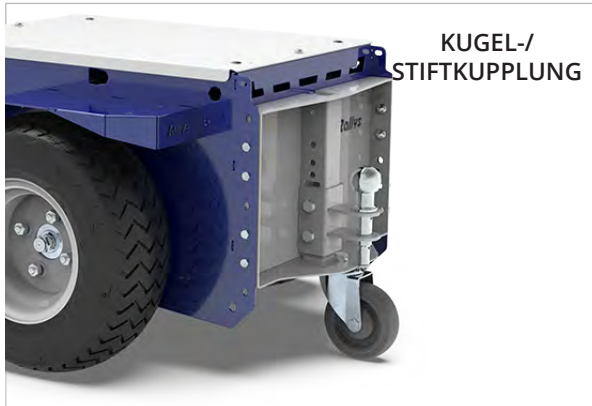



# ZUBEHÖRTEILE





# Anwendungsbeispiele

---

in den verschiedenen Produktionssektoren



# METALLINDUSTRIE

**Zollys**  
... the passion for moving





# INDUSTRIELLE INSTANDHALTUNG

**Zollis**  
... the passion for moving





# FLUGHÄFEN

**Zolllys**  
... the passion for moving



# ABFALLBEHANDLUNG

**Zallys**  
... the passion for moving





# Zallys®

• • • the passion for moving

Zallys srl srl - Via Palazzina 1, Sarcedo  
36030 (VI) - Italia

## Contatti:

sales@zallys.com  
+39 0445 366785

## Web site:

[www.zallys.com](http://www.zallys.com)

