



M12

Movimentatore elettrico industriale

M12

Z178.720



5,0 km/h



1.500 kg



15 %

- Per carichi fino a 1.500 kg.
- Versatile e compatto.
- Pacchi batterie intercambiabili
- Selettore di velocità a 5 livelli.
- Ampia gamma di accessori e connessioni.
- Possibilità di guida con radiocomando.

👁 **Vista Frontale**



👁 **Vista Laterale**



👁 **Vista Posteriore**





	TABLE: Z178.720	M12	Unit: mm [inch]
--	---------------------------	------------	-----------------

Settori principali



INDUSTRIA
AUTOMOBILISTICA



INDUSTRIA
METALLURGICA
E TORNERIE



INDUSTRIA
FERROVIARIA



INDUSTRIA
DEL VETRO



INDUSTRIA
TESSILE



MANUTENZIONE
INDUSTRIALE



LAVANDERIE E AZIENDE
MULTISERVIZIO



INDUSTRIA
ALIMENTARE



AEROPORTI



OSPEDALI

Prestazioni su pendenza

Fermo restando invariata la forza al gancio espressa in N, la capacità di traino espressa in kg **può variare in base a:**

- **tipo di terreno** sul quale viene effettuato il traino;
- traino su suolo **piano o in pendenza**;
- utilizzo o meno di **zavorre**;
- **tipo di ruote** montate su macchina e carrello.

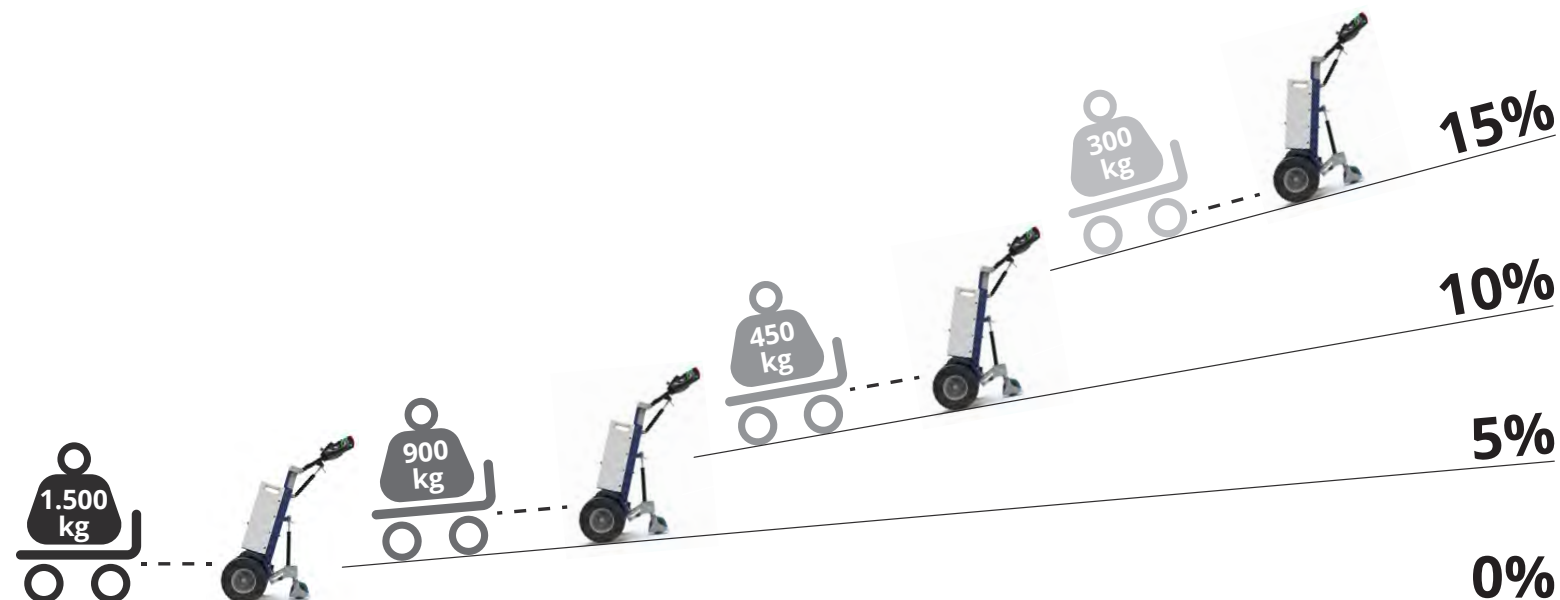

Regolazione della velocità a 5 livelli

Sul nuovo timone di JESPI firmato Zallys troviamo montato **di serie** un pulsante per regolare la velocità della macchina. Premendolo, ad ogni click si passa alla marcia successiva. Ciò permette una rapida e comoda selezione della velocità adeguata al tipo di manovra da affrontare. Il sistema **Flex-to-Go** è stato studiato per avere maggiore manovrabilità negli spazi ristretti e più velocità nei tragitti lunghi.

Ogni click aggiunge il **20% di velocità in più** rispetto alla marcia precedente.

Rampa velocità:

20% - 40% - 60% - 80% - 100%

Una volta arrivati alla quinta marcia, premendo il pulsante si ritorna alla prima.

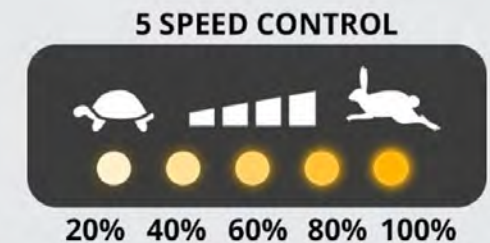

Guida ergonomica

La testata Zallys è stata studiata e realizzata per rendere più ergonomico l'utilizzo della macchina da parte dell'operatore, garantendo il giusto **comfort su un uso prolungato** durante il turno di lavoro. Il suo **design ergonomico** permette di avere **tutti i pulsanti dei comandi a portata di mano**, il display con indicata la carica residua della batteria e la chiave per un'accensione veloce e comoda. La **struttura** è composta da **materiali resistenti** in caso di urti accidentali.

Chiave di accensione

Pulsante selezione
velocità

Pulsante
anti-schiacciamento



..... Pannello di controllo

..... Pulsante avvisatore
acustico

..... Comandi di marcia ad
azione mantenuta

Le ruote giuste per ogni esigenza

M12 monta di serie **ruote pneumatiche**, adatte sia per l'utilizzo all'interno che all'esterno, per garantire sempre la massima aderenza a terra e un bassissimo livello di vibrazioni. Inoltre, sono molto resistenti e offrono prestazioni eccezionali su qualsiasi terreno. Su richiesta è possibile montare altri tipi di gommatura, come ad esempio le **ruote piene "superelastiche antitraccia"**, per le pavimentazioni delicate.



Pacchi batterie intercambiabili 24/7

I pacchi batterie sono leggeri e facilmente **intercambiabili** in modo da poter coprire più turni di lavoro: quando se ne scarica uno si può metterlo in carica e sostituirlo immediatamente con uno già carico, in questo modo la macchina sarà sempre attiva! Inoltre sono **disponibili diversi amperaggi** a seconda delle esigenze: 30Ah, 45Ah ad AGM o 40Ah al Litio.



33Ah - AGM



45Ah - AGM



40Ah - Litio

Sistema di zavorre modulare

Il **sistema modulare Zallys** garantisce la **massima flessibilità** nell'aumentare le prestazioni del veicolo. Con un **peso unitario di soli 4 kg**, le singole zavorre sono leggere e possono essere equipaggiate **senza sforzo fisico da parte dell'operatore**, pur mantenendo tutta la loro efficacia.



GANCI STANDARD



GANCIO CON
SFERA-PERNO



GANCIO CON
SPINA



GANCIO PINZA
ELETTRICA



SUPPORTO A SCORIMENTO
ELETTRICO



GANCIO PER CONTENITORE
DELLA SPAZZATURA



GANCIO PER ROLL
BOX REGOLABILE

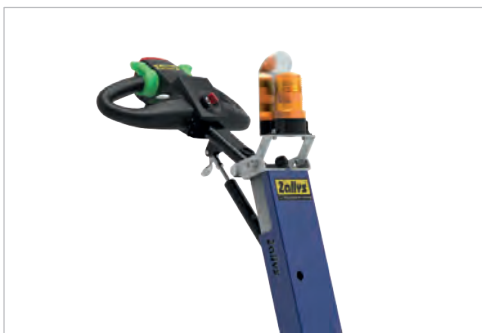

GIRO FARO

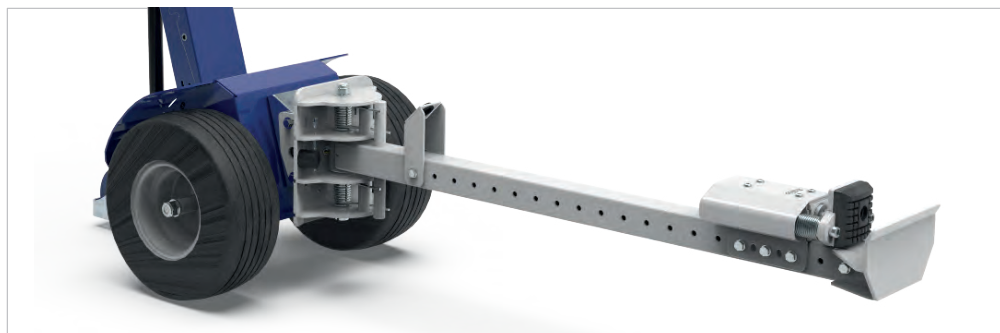

GANCIO PINZA
IDRAULICA



Esempi di applicazione

nei vari settori produttivi



INDUSTRIA AUTOMOBILISTICA

Zollis
... the passion for moving





INDUSTRIA METALLURGICA

Zollis
the passion for moving





INDUSTRIA FERROVIARIA

Zollis
... the passion for moving



INDUSTRIA DEL VETRO

Zallys
... the passion for moving





INDUSTRIA TESSILE

Zollux
... the passion for moving





MANUTENZIONE INDUSTRIALE

Zallys®
the passion for moving





LAVANDERIE E MULTISERVIZIO

Zollis
... the passion for moving





INDUSTRIA ALIMENTARE

Zollis
... the passion for moving





OSPEDALI

Zollys
... the passion for moving





• • • the passion for moving

Zallys srl srl - Via Palazzina 1, Sarcedo
36030 (VI) - Italia

Contatti:

sales@zallys.com
+39 0445 366785

Web site:

www.zallys.com



A close-up photograph of a blue, textured surface, possibly a piece of equipment or a container. The word "Zallys" is embossed or printed in a raised, metallic-looking font on the surface. The background is blurred, showing other parts of the equipment.



M12

Vertical electric tug

M12

Z178.720



5,0 km/h



1.500 kg



15 %

- For loads up to 1.500 kg.
- Versatile and compact.
- Interchangeable battery packs.
- 5-levels speed adjustment.
- Wide range of accessories and connections.
- Optional remote control driving.

👁 **Front View**



👁 **Side View**



👁 **Rear View**





	TABLE: Z178.720	M12	Unit: mm [inch]
--	---------------------------	------------	-----------------

Main sectors



AUTOMOTIVE
INDUSTRY



METALLURGICAL
AND TURNING
INDUSTRY



RAILWAY
INDUSTRY



GLASS
INDUSTRY



TEXTILE
INDUSTRY



INDUSTRIAL
MAINTENANCE



LAUNDRIES AND
MULTISERVICE
COMPANIES



FOOD INDUSTRY



AIRPORTS



HOSPITALS

Performances on slopes

While the force expressed in N at the hook remains unchanged, the following circumstances **may affect the towing capacity expressed in kg:**

- **type of ground** on which the towing is performed;
- towing on **flat ground or on a slope**;
- use (or not) of **ballasts**;
- **type of wheels** mounted on the vehicle and on the trailer.

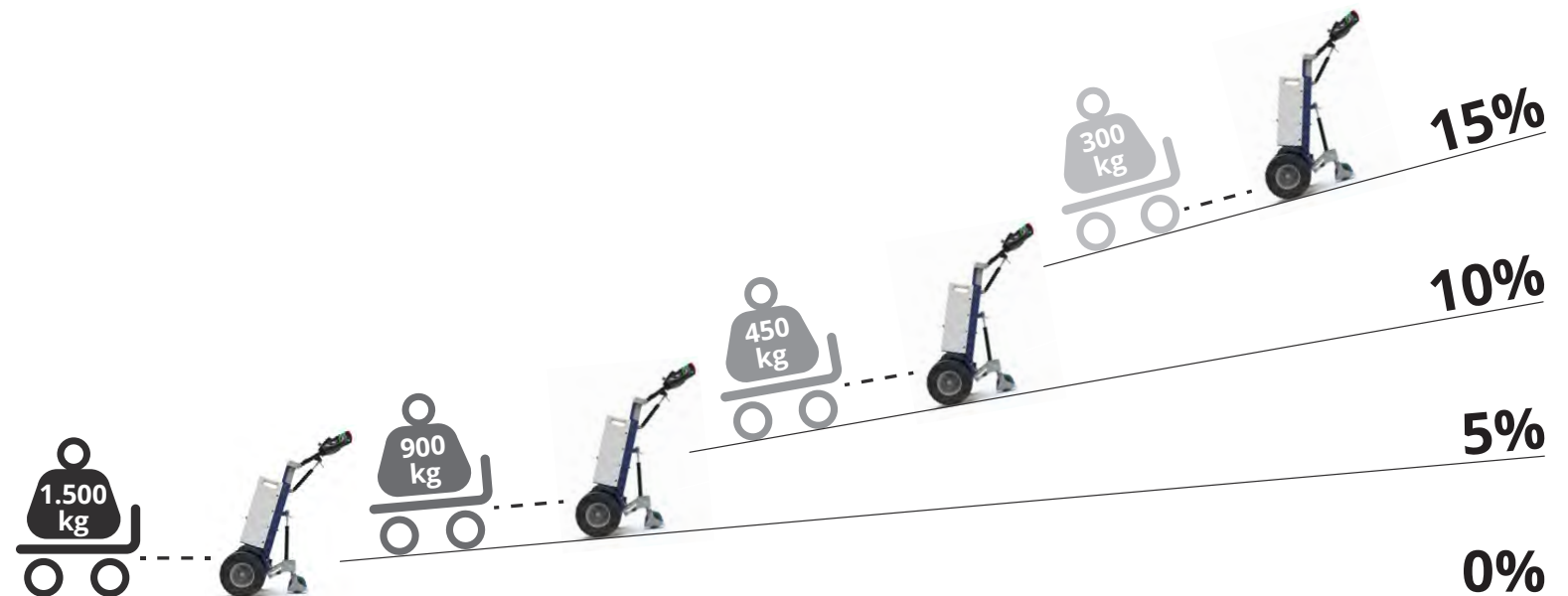

5 levels speed adjustment

On the new M12 tillerhead by Zallys is mounted **as standard** a button for the adjustment of the speed of the machine. By clicking it, at each click you switch to the next level. This allows a fast and easy selection of the correct speed based on the kind of manoeuvre. **The Flex-to-Go system** has been studied to give a better maneuverability in confined spaces and more speed on the longer journeys.

Each click adds **20% more speed**.

Speed ramp:

20% - 40% - 60% - 80% - 100%

Once the maximum speed is reached, by pressing the button again it returns to 20%.

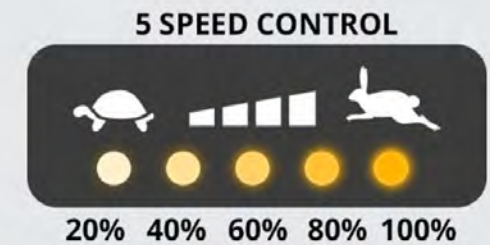

Ergonomic driving

Zallys' tillerhead has been conceived and produced to make the use of the machine more ergonomic for the operator, guaranteeing the right **comfort while driving during the work shift**. Its **ergonomic design** allows to have **all the driving controls at your fingertips**, the display with the battery charge level and the power key for an easy and fast ignition. **The structure** is made of **resistant materials** in case of accidental bumps.

Power key

5 speed selection

Anti-crush reverse button



Dashboard

Acoustic alarm

Maintained action drive controls



The right wheels for every need

JACK mounts **pneumatic wheels** as standard, suitable for both indoor and outdoor use, and guarantee the maximum grip and a very low level of vibrations. Moreover, they are really resistant and offer exceptional performances on every terrain. On request it is possible to put on a different kind of wheels, such as **Tractor wheels** for irregular or uneven terrains, or the **“non-marking superelastic” wheels**, for delicate floorings.

Interchangeable battery packs 24/7



33Ah - AGM

45Ah - AGM

40Ah - Litio

Battery packs are lightweight and easily **interchangeable** in order to cover several work shifts: when one is discharged you can put it in charge and immediately replace it with a fully charged one. This way, the machine is always operating! Moreover, **different amperages** are available according to your needs: 33Ah, 45Ah AGM or 40Ah Lithium



Modular ballast system

Zallys modular system guarantees **maximum flexibility** on increasing the vehicle's performances. With just **4 kg unit weight**, single ballasts are lightweight and can be equipped **without physical effort by the operator**, while maintaining all their effectiveness.

STANDARD HITCH



BALL/PIN
HITCH



DROP PIN
HITCH



ELECTRIC
CLAMP HITCH



HEIGHT ADJUSTABLE PLATE
ELECTRIC CONTROLLED



HITCH FOR
TRASH BINS



ADJUSTABLE HITCH
FOR ROLL BOX



LED STROBE LIGHT

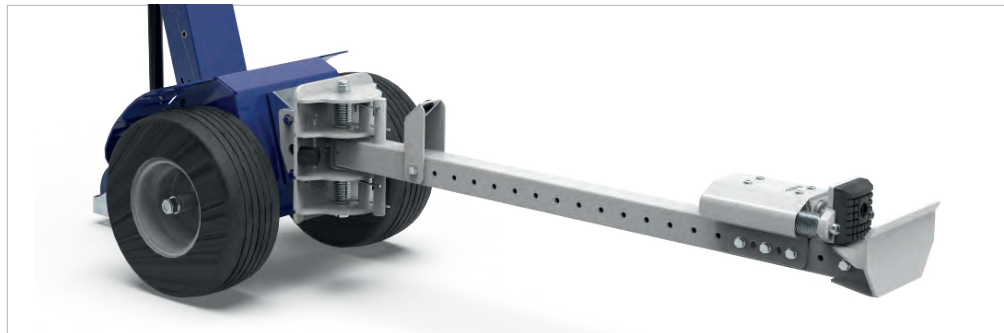

HYDRAULIC
CLAMP HITCH



Examples of applications

on various production sectors



AUTOMOTIVE INDUSTRY

Zollis
... the passion for moving





METALLURGICAL INDUSTRY

Zollis
the passion for moving





RAILWAY INDUSTRY

Zollys
... the passion for moving



GLASS INDUSTRY

Zallys
... the passion for moving





TEXTILE INDUSTRY

Zollux
... the passion for moving





INDUSTRIAL MAINTENANCE

Zallys
the passion for moving





LAUNDRIES AND MULTISERVICE

Zallys
... the passion for moving





FOOD INDUSTRY

Zollis
... the passion for moving



HOSPITALS

Zollys
... the passion for moving





• • • the passion for moving

Zallys srl srl - Via Palazzina 1, Sarcedo
36030 (VI) - Italia

Contacts:

sales@zallys.com
+39 0445 366785

Web site:

www.zallys.com





M12

Timon électrique

M12

Z178.720



5,0 km/h



1.500 kg



15 %

- Pour des charges jusqu'à 1500 kg
- Polyvalent et compact
- Batterie interchangeable pour garantir 24/7
- Bouton pour le réglage à 5 vitesses
- Large gamme des attelages et accessoires.
- Kit télécommande sur demande .

👁 **Vue de Face**



👁 **Vue Latérale**



👁 **Vue Arrière**





	TABLE: Z178.720	M12	Unit: mm [inch]
--	---------------------------	------------	-----------------

Principaux secteurs



INDUSTRIE
AUTOMOBILE



INDUSTRIE
MÉTALLURGIQUE
ET DU TOURNAGE



INDUSTRIE
FERROVIAIRE



INDUSTRIE
DU VERRE



INDUSTRIE
TEXTILE



MAINTENANCE
INDUSTRIELLE



SERVICES DE
BLANCHISSERIE ET DE



INDUSTRIE
ALIMENTAIRE



AÉROPORTS



HÔPITAUX

Performances de traction

Compte tenu des valeurs standard de l'effort de traction max au crochet en N, la capacité de traction en kg **peut varier selon**:

- **type de sol** où on travaille;
- traction sur **plan or en pente**;
- utilisation ou **pas de lests**;
- **typologies de roues** de la machine et du chariot.

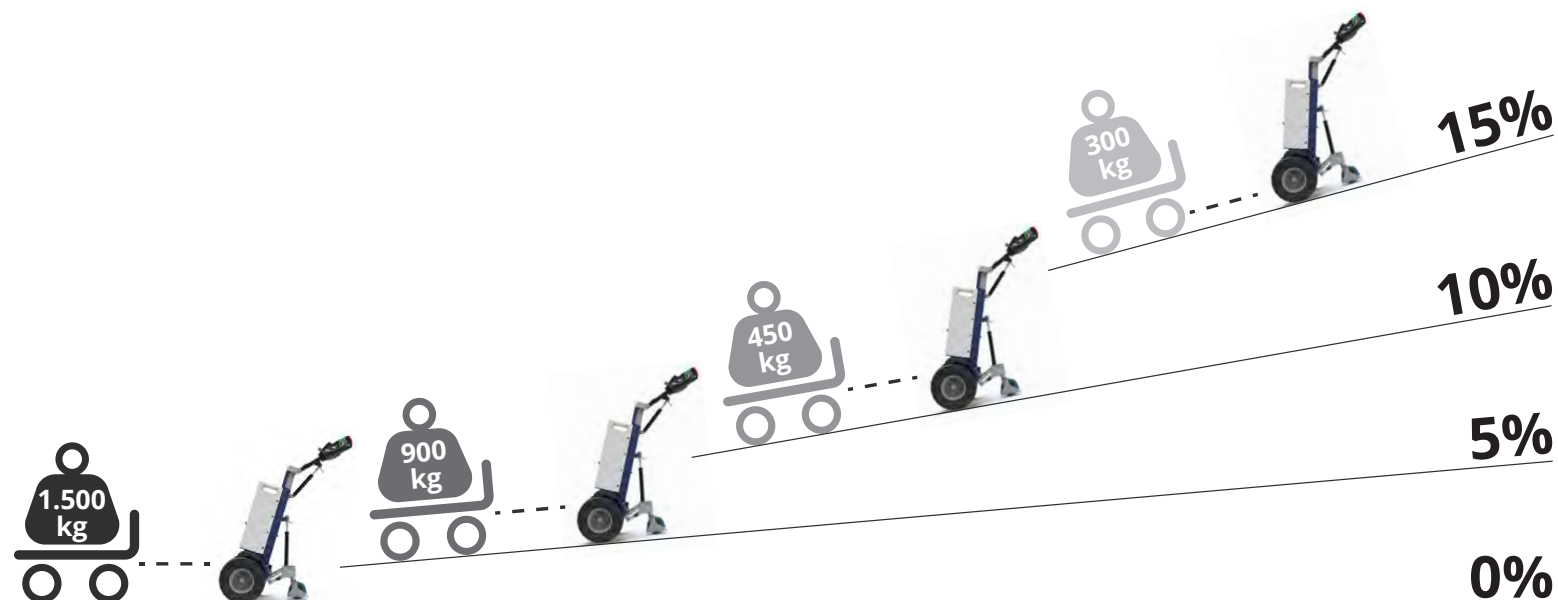

Interrupteur 5 vitesses

Le bouton à 5 vitesses est monté de série sur le nouvel timon Zallys du M12. En y appuyant dessus, à chaque clique, vous passez au step suivant. Cela permet une sélection rapide et pratique de la vitesse correcte pour le type de manœuvre que l'opérateur doit faire. Le système Flex-to-Go a été conçu pour apporter une plus grande maniabilité dans les espaces étroits et plus de vitesse sur les longues distances.

Chaque clique ajoute **20% de vitesse de plus** que l'étape précédente.

Valeurs vitesse:

20% - 40% - 60% - 80% - 100%

Quand la vitesse est au maximum, en appuyant à nouveau sur le bouton, elle revient au 20%.

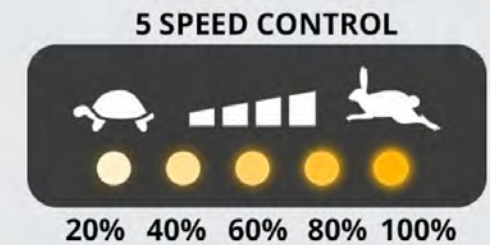

Conduite ergonomique

La tête du timon Zallys est pensée pour rendre l'utilisation de la machine la plus ergonomique possible pour l'opérateur, en garantissant le correct **confort pendant un usage prolongé** sur le lieu du travail. **Toutes les commandes à portée de main**: dans le tableau de bord, des voyants à LED sont toujours visibles, le niveau de charge aussi et la clé pour permettre un allumage vite et confortable. **La structure est faite avec matériaux résistants** aux chocs accidentels.

Interrupteur à clé

Bouton pour
selectionner la vitesse

Bouton
anti-écrasement



..... Panneau de commande

..... Klaxon

..... Commande à action
maintenue

Le ruote giuste per ogni esigenza

M12 monta di serie **ruote pneumatiche**, adatte sia per l'utilizzo all'interno che all'esterno, per garantire sempre la massima aderenza a terra e un bassissimo livello di vibrazioni. Inoltre, sono molto resistenti e offrono prestazioni eccezionali su qualsiasi terreno. Su richiesta è possibile montare altri tipi di gommatura, come ad esempio le **ruote piene "superelastiche antitraccia"**, per le pavimentazioni delicate.



Pack batteries interchangeable 24/7

Les packs batteries sont légers et **interchangeables** très facilement, afin de garantir le fonctionnement de la machine 24 heures et 7 jours: quand le pack a besoin d'être rechargé, on va le remplacer avec un autre, sans stopper la machine pour la recharger! De plus, on propose **2 différentes typologies selon les exigences**: 30Ah et 45Ah AGM ou 40Ah Lithium.



33Ah - AGM



45Ah - AGM



40Ah - Litio

Système modulaire de lests

Le **système modulaire Zallys** garantit une flexibilité maximale en augmentant les performances du véhicule. Chaque lest a un **poids unitaire de 4 kg**: elles sont très légères et l'opérateur peut les manipuler sans aucun effort physique pour l'opérateur.



CROCHETS STANDARD



BOULE/TIGE
CROCHET



ATTELAGE
À GOUPILLE



CROCHET À PINCE
ÉLECTRIQUE



SUPPORT
COULISSANT ÉLECTRIQUE



ATTELAGE POUR
POUBELLES



GANCIO PER ROLL
BOX REGOLABILE



GYROPHARE

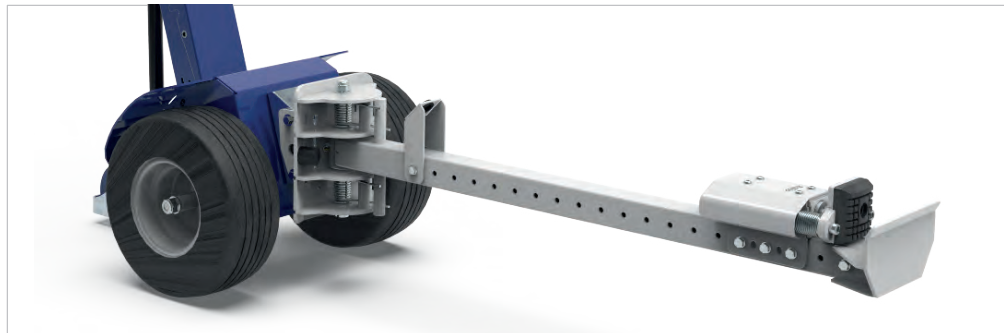

CROCHET À PINCE
HYDRAULIQUE



Exemples d'applications

Dans les différents secteurs productifs



INDUSTRIE AUTOMOBILE

Zollys
... the passion for moving





INDUSTRIE MÉTALLURGIQUE

Zallys
the passion for moving





INDUSTRIE FERROVIAIRE

Zollys
... the passion for moving



INDUSTRIE DU VERRE

Zallys
... the passion for moving





INDUSTRIE TEXTILE

Zollux
... the passion for moving





MAINTENANCE INDUSTRIELLE

Zollys
the passion for moving





SERVICES DE BLANCHISSERIE ET DE NETTOYAGE

Zollis
the passion for moving





INDUSTRIE ALIMENTAIRE

Zollis
... the passion for moving







• • • the passion for moving

Zallys srl srl - Via Palazzina 1, Sarcedo
36030 (VI) - Italia

Contatti:

sales@zallys.com
+39 0445 366785

Web site:

www.zallys.com



The word "Zallys" is embossed in a metallic, three-dimensional font onto a blue, textured surface, possibly a piece of equipment or a storage container. The background of the entire image is a blurred close-up of mechanical parts in white and blue.



M12

Remolcador eléctrico industrial

M12

Z178.720



5,0 km/h



1.500 kg



15 %

- Para cargas de hasta 1.500 kg.
- Versátil y compacto
- Paquete de baterías intercambiables
- Selector de velocidad de 5 niveles.
- Amplia gama de accesorios y conexiones.
- Posibilidad de conducir con radiocontrol.

Vista Frontal



Vista Lateral



Vista Trasera





	TABLE: Z178.720	M12	Unit: mm [inch]
--	---------------------------	------------	-----------------

Sectores principales



INDUSTRIA AUTOMOTRIZ



INDUSTRIA METALÚRGICA Y DE TORNEADO



INDUSTRIA FERROVIARIA



INDUSTRIA DEL VIDRIO



INDUSTRIA TEXTIL



MANTENIMIENTO INDUSTRIAL



LAVANDERÍAS Y EMPRESAS MULTISERVICIO



INDUSTRIA DE ALIMENTOS



AEROPUERTOS



HOSPITALES

Rendimiento de remolque

Sin cambiar la fuerza sobre el gancho expresada en N, la capacidad de remolque expresada en kg **puede variar en función de:**

- **tipo de terreno** en el que se lleva a cabo el remolque;
- **remolque en terreno** plano o inclinado;
- **uso o no** de contrapesos;
- **tipo de ruedas** montadas en la máquina y carro.

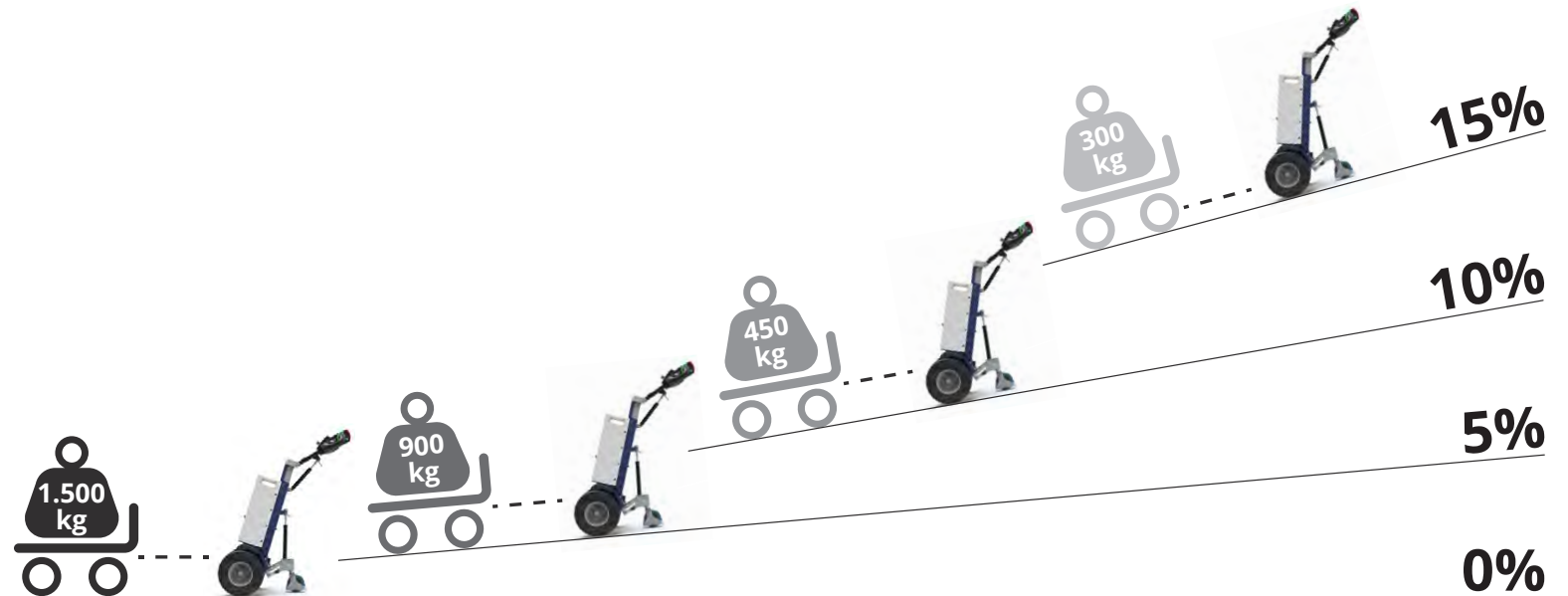

Ajuste de velocidad de 5 niveles

En el **nuevo timón Zallys M12** encontramos un botón para ajustar la velocidad de la máquina **de serie**. Al presionarlo, cada clic cambia a la siguiente marcha. Esto permite una selección rápida y cómoda de la velocidad adecuada al tipo de maniobra a afrontar. El **sistema Flex-to-Go** ha sido diseñado para tener una mayor maniobrabilidad en espacios reducidos y más velocidad en viajes largos.

Cada clic **agrega un 20% más de velocidad** que la marcha anterior.

Rampa de velocidad:

20% - 40% - 60% - 80% - 100%

Una vez en la quinta marcha, al presionar el botón se vuelve a la primera

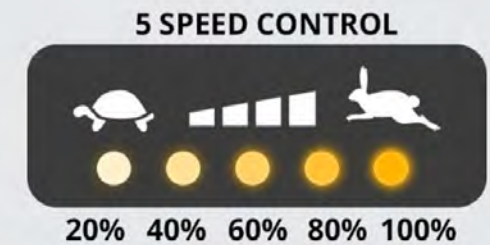

Conducción ergonómica

El **cabezal Zallys** ha sido diseñado y construido para hacer más ergonómico el uso de la máquina por parte del operador, asegurando la **comodidad adecuada en un uso prolongado** durante el turno de trabajo. Su **diseño ergonómico** permite tener **todos los botones de control al alcance de la mano**, la pantalla indica la carga restante de la batería y la llave para un encendido rápido y conveniente. La **estructura** está fabricada con **materiales resistentes** en caso de impactos accidentales.

Llave de contacto

Botón de selección de
velocidad

Botón
anti-aplastamiento



..... Panel de control

..... Mandos de marcha
con acción mantenida

..... Botón de la bocina

Las ruedas adecuadas para cada necesidad



M12 está equipado de serie con **ruedas neumáticas**, aptas tanto para uso interior como exterior, para garantizar siempre la máxima adherencia al suelo y un nivel muy bajo de vibraciones. Además, son muy duraderas y ofrecen un rendimiento excepcional en cualquier terreno. Bajo pedido es posible montar otros tipos de neumáticos, como **ruedas macizas “superelásticas que no dejan huellas”**, para suelos delicados.

Paquetes de baterías intercambiables 24/7



33Ah - AGM

45Ah - AGM

40Ah - Litio

Los paquetes de baterías son ligeros y fácilmente **intercambiables** para que puedan cubrir múltiples turnos de trabajo: cuando uno está descargado, se puede cargar y reemplazar inmediatamente por uno ya cargado, de esta manera la máquina siempre estará activa. Además, **se encuentran disponibles diferentes amperajes** según las necesidades: 30Ah, 45Ah con AGM o 40Ah con Litio.

Sistema de contrapesos modular



El **sistema modular de Zallys** garantiza la **máxima flexibilidad** para aumentar el rendimiento del vehículo. Con un **peso unitario de solo 4 kg**, los contrapesos individuales son ligeros y el operador puede equiparlos **sin esfuerzo físico**, manteniendo toda su eficacia.

GANCHOS ESTÁNDAR



GANCHO
BOLA/PIN



GANCHO
CON PERNO



GANCHO CON
PINZA ELÉCTRICA



SOPORTE
DESLIZANTE ELÉCTRICO



GANCHO PARA
CONTENEDORES DE BASURA



GANCHO AJUSTABLE
PARA ROLL BOX



FARO
GIRATORIO LED

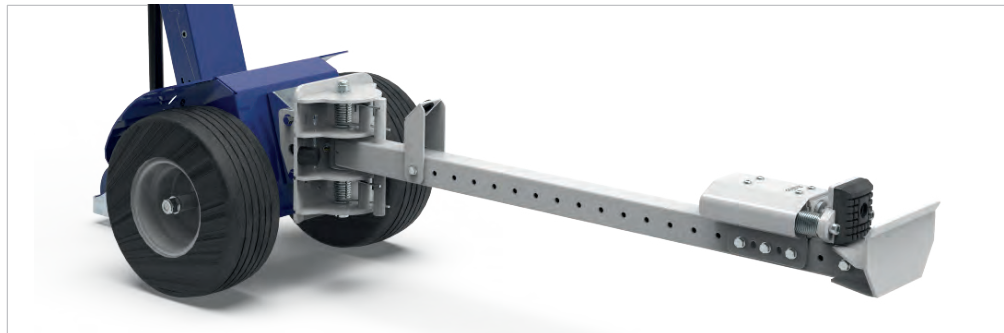

GANCHO CON
PINZA HIDRÁULICA



Ejemplos de aplicación

en los distintos sectores productivos



INDUSTRIA AUTOMOTRIZ

Zallys
... the passion for moving





INDUSTRIA METALÚRGICA

Zollis
the passion for moving





INDUSTRIA FERROVIARIA

Zollis
... the passion for moving



INDUSTRIA DEL VIDRIO

Zallys
... the passion for moving





INDUSTRIA TEXTIL

Zollux
... the passion for moving





MANTENIMIENTO INDUSTRIAL

Zallys®
the passion for moving





LAVANDERÍAS Y MULTISERVICIO

Zollis
... the passion for moving





INDUSTRIA DE ALIMENTOS

Zollis
... the passion for moving



HOSPITALES

Zollys
... the passion for moving





• • • the passion for moving

Zallys srl srl - Via Palazzina 1, Sarcedo
36030 (VI) - Italia

Contatos:

sales@zallys.com
+39 0445 366785

Web site:

www.zallys.com



A close-up photograph of a blue, textured surface, possibly a piece of equipment or a bag. The word "Zallys" is embossed or printed in a raised, metallic-looking font on the surface. The background is blurred, showing parts of a white and grey object.



M12

Elektrische Schlepphilfe

M12

Z178.720



5,0 km/h



1.500 kg



15 %

- Für Lasten bis 1.500 kg.
- Vielseitig und kompakt.
- Austauschbarer Akku.
- Taste zur 5-Gang-Einstellung.
- Große Auswahl an Zubehörteile.
- Möglichkeit des Fahrens mit Fernbedienung.

👁 Vorderansicht



👁 Seitenansicht



👁 Rückansicht





	TABLE: Z178.720	M12	Unit: mm [inch]
--	---------------------------	------------	-----------------

Hauptsektoren



AUTOMOBILINDUSTRIE



HÜTTEN- UND
DREHINDUSTRIE



EISENBAHNINDUSTRIE



GLASINDUSTRIE



TEXTILINDUSTRIE



INDUSTRIEWARTUNG



WÄSCHEREIN UND
MULTISERVICE-
UNTERNEHMEN



NAHRUNGSMITTELINDUSTRIE



FLUGHÄFEN



KRANKENHÄUSER

Leistungen auf Gefälle

Bei unveränderter Hakenkraft in N kann die **Zugkraft in kg** je nach:

- **Boden**-Typologie;
- Schleppnetz auf ebenem oder **geneigtem Boden**;
- Verwendung oder **Nichtverwendung von Ballast**;
- **Räder** Typologie.

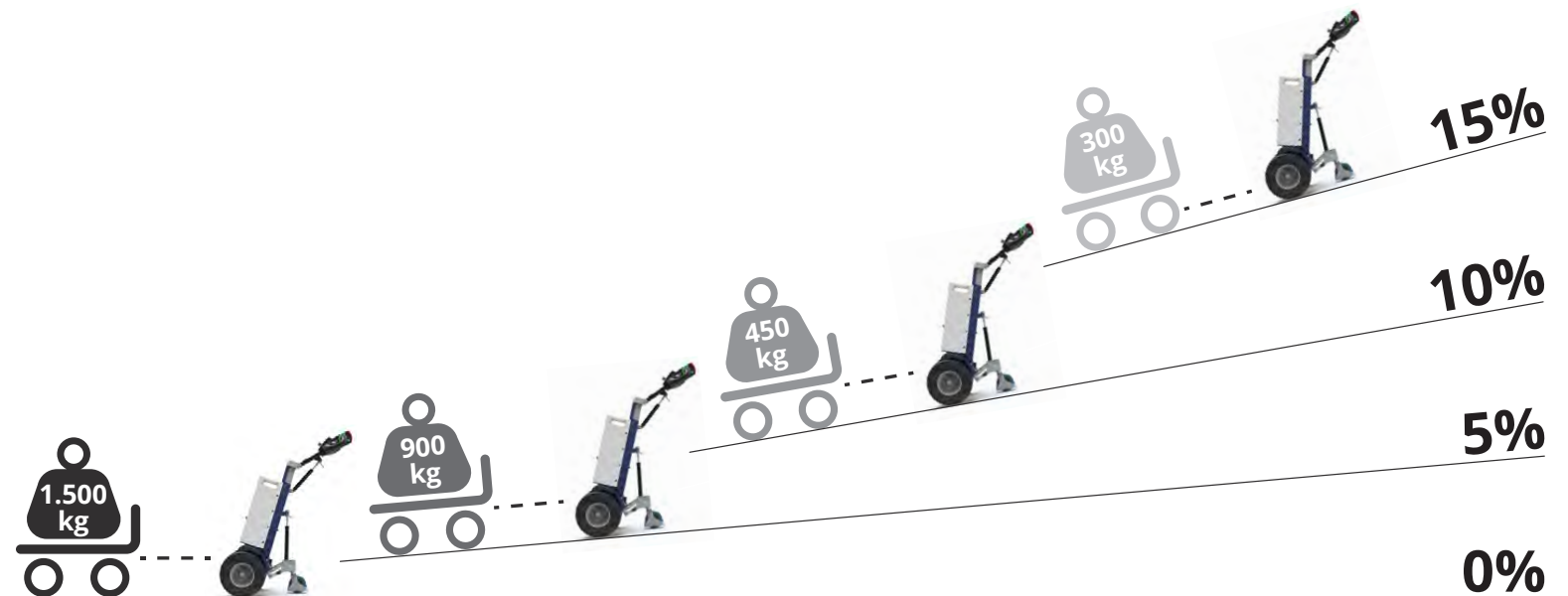

Einstellung der Geschwindigkeit in 5 Stufen

Auf dem neuen M12-Steuerruder von Zallys finden wir serienmäßig einen Knopf zur Einstellung der Geschwindigkeit der Maschine montiert. Mit jedem Klick gehen Sie zum nächsten Gang. Dies ermöglicht eine schnelle und bequeme Wahl der Geschwindigkeit, die der Art des zu bewältigenden Manövers angemessen ist. **Das Flex-to-Go-System** wurde entwickelt, um eine bessere Manövrierbarkeit auf engstem Raum und eine höhere Geschwindigkeit auf langen Strecken zu erreichen. Jeder Klick erhöht die **Geschwindigkeit um 20%** gegenüber dem vorherigen Gang.

Geschwindigkeitsrampe:

20% - 40% - 60% - 80% - 100%

Sobald Sie den fünften Gang erreicht haben, drücken Sie den Knopf und kehren Sie in den ersten Gang zurück.

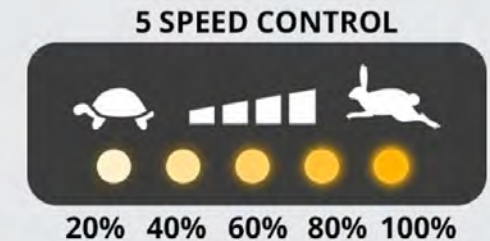

Ergonomische Führung

Der Zallys-Kopfstoß wurde entwickelt, um die Bedienung der Maschine durch den Bediener ergonomischer zu gestalten und den richtigen **Komfort bei längerer Benutzung** während der Schicht zu gewährleisten. **Das ergonomische Design** ermöglicht es Ihnen, alle Bedientasten griffbereit zu haben, das Display mit Angabe der verbleibenden Akkuladung und den Schlüssel für eine schnelle und bequeme Zündung. **Die Struktur besteht aus widerstandsfähigen Materialien** bei versehentlichen Stößen.

Zündschlüssel

Geschwindigkeitsauswahlknopf

Anti-
Zerquetschen Knopf



..... Bedienfeld

..... Taste für akustische
Warnvorrichtung

..... Dauerbetätigungseinrichtungen

Die richtigen Räder für jeden Bedarf

M12 montiert serienmäßig Lufträder, die sowohl für den Einsatz im Innen- als auch im Außenbereich geeignet sind, um stets eine maximale Bodenhaftung und ein sehr niedriges Vibrationsniveau zu gewährleisten. Darüber hinaus sind sie sehr widerstandsfähig und bieten außergewöhnliche Leistung auf jedem Gelände. Auf Wunsch können auch andere Gummierungstypen, wie z.B. «**superelastische Antispur**»-Füllräder, für empfindliche Böden montiert werden.



Austauschbarer Akku für 24/7 Garantie

Die Batteriesätze sind leicht und **leicht austauschbar**, so dass Sie mehrere Arbeitsschichten abdecken können: Wenn Sie einen entladen haben, können Sie ihn aufladen und sofort durch einen bereits geladenen ersetzen, so dass die Maschine immer aktiv ist! Darüber hinaus sind **verschiedene Stromstärken** je nach Bedarf erhältlich: 30Ah, 45Ah bei AGM oder 40Ah bei Lithium.



33Ah - AGM



45Ah - AGM



40Ah - Litio

Modulares Ballastsystem

Das **modulare System von Zallys** bietet maximale Flexibilität bei der Steigerung der Fahrzeugleistung. **Mit einem Stückgewicht von nur 4 kg sind** die einzelnen Ballastgeräte leicht und können ohne körperliche Anstrengung des **Bedieners ausgerüstet werden**, ohne dabei jedoch ihre volle Leistungsfähigkeit zu verlieren.



STANDARD HAKEN

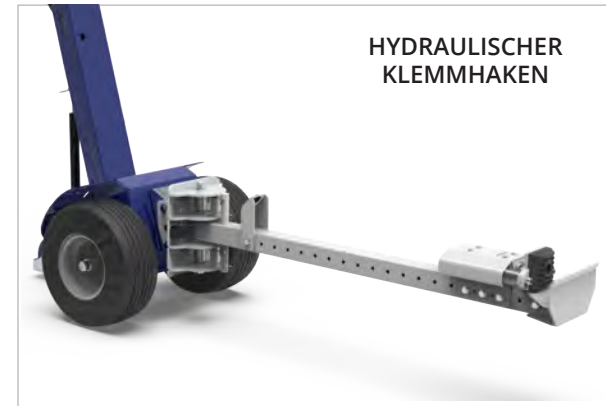
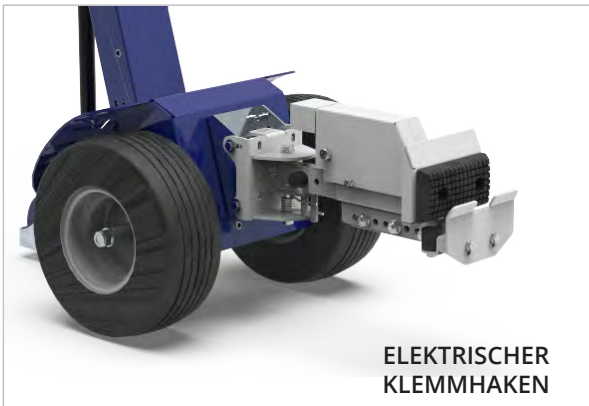
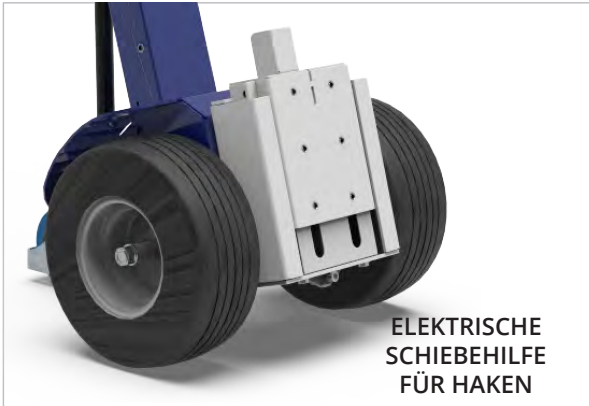

ZÜBEHÖRTEILE





Anwendungsbeispiele

in den verschiedenen Produktionssektoren



AUTOMOBILINDUSTRIE

Zollis
... the passion for moving





METALLINDUSTRIE

Zolllys
the passion for moving





EISENBAHNINDUSTRIE

Zollys
... the passion for moving







TEXTILINDUSTRIE

Zollux
... the passion for moving





INDUSTRIEWARTUNG

Zallys
the passion for moving





WÄSCHEREIN UND MULTISERVICE-UNTERNEHMEN

Zollis
... the passion for moving





NAHRUNGSMITTELINDUSTRIE

Zollys
... the passion for moving





KRANKENHÄUSER

Zollys
... the passion for moving





• • • the passion for moving

Zallys srl srl - Via Palazzina 1, Sarcedo
36030 (VI) - Italia

Contacts:

sales@zallys.com
+39 0445 366785

Web site:

www.zallys.com



The word 'Zallys' is embossed in a 3D, metallic blue font onto a textured blue surface, likely a piece of equipment. The background of the entire page is a blurred image of a white and blue mechanical device.